

Rampion 2 Wind Farm

Category 6:

Environmental Statement

Volume 4, Appendix 23.2: Traffic Generation Technical Note (clean)

Date: August 2024

Revision E

Document Reference: 6.4.23.2

Pursuant to: APFP Regulation 5 (2) (a)

Ecodoc number: 004866580-05



Document revisions

Revision	Date	Status/reason for issue	Author	Checked by	Approved by
A	04/08/2023	Final for DCO Application	WSP	RED	RED
B	28/02/2024	Update for ES Addendum	WSP	RED	RED
C	25/04/2024	Update for Deadline 3	WSP	RED	RED
D	09/07/2024	Deadline 5 update to reflect individual construction access routing controls set-out within the Technical Note Construction Access Update Assessment Summary [REP3-055] and heavy goods vehicle (HGV) routing to reflect controls related to the traffic management strategies in Appendix D within the Outline Construction Traffic Management Plan [REP4-045] .	WSP	RED	RED
E	01/08/2024	Update for Deadline 6 including references to baseline traffic flows for Kent Street and Michelgrove Lane to reflect traffic surveys completed between 08 and 14 May 2024.	WSP	RED	RED

Contents

1.	Introduction	7
1.1	Overview	7
1.2	Context	7
1.2	Structure of this Appendix:	8
2.	Relevant legislation, policy and other information and guidance	9
2.1	Introduction	9
2.2	National planning policy	9
2.3	Other relevant information and guidance	18
3.	Existing Transport Network	21
3.1	Study Area 1 – onshore	21
	Strategic Road Network	21
	Local Highway Network	22
	Baseline traffic flows	26
3.2	Study Area 2 – onshore impacts of offshore works	33
	Strategic Road Network	34
	Local Highway Network	34
	Baseline traffic flows	35
	Future baseline	37
4.	Proposed Development	41
4.1	The onshore elements of the Proposed Development	41
4.2	The offshore elements of the Proposed Development	44
5.	Key Construction Traffic Assumptions	47
5.1	Introduction	47
5.2	Overview	47
5.3	Onshore cable corridor	47
5.4	Temporary construction compounds	51
5.5	Onshore substation	51
5.6	Work section breakdown	52
5.7	Construction activities	52
5.8	Construction Management Base	53
5.9	Scheduling	54

5.10	Construction materials, personnel, plant and equipment requirements	54
6.	Construction traffic generation	56
6.3	Construction Traffic Distribution	57
6.6	ES Addendum Further Sensitivity Tests	66
7.	Operation and maintenance traffic generation	75
7.1	Overview	75
7.2	Traffic generation	75
8.	Decommissioning traffic generation	77
8.1	Onshore decommissioning	77
	Onshore cable	77
	Onshore substation	77
	Offshore	78
9.	Glossary of terms and abbreviations	79
10.	References	81

List of Tables

Table 2-1	National planning policy relevant to transport	9
Table 2-2	Local transport / planning policy relevant to transport	14
Table 3-1	A/B roads within Study Area 1	21
Table 3-2	2021 baseline traffic data (AADF) – Study Area 1	28
Table 3-3	Baseline data – 2022 Traffic survey	30
Table 3-5	A/B Roads within Study Area 2	34
Table 3-6	2021 baseline traffic data (AADF) – Study Area 2	36
Table 5-1	Accesses	48
Table 6-1	Two-way vehicle movement summary	57
Table 6-2	HGV construction traffic distribution	58
Table 6-3	HGV access routes	58
Table 6-4	LGV access routes	59
Table 6-5	LGV construction staff traffic distribution	60
Table 6-6	MOV circular construction routes	61
Table 6-7	Total two-way construction movements by access	62
Table 6-8	Peak weekly movements by access	69
Table 6-9	Onshore construction traffic impact per receptor	71
Table 6-10	Onshore construction traffic impact per new receptors	73
Table 7-1	Onshore operation and maintenance traffic percentage impact per highways link – Study Area 2	76
Table 8-1	Onshore substation decommissioning traffic percentage impact per highways link	78

List of Graphics

Graphic 5-1	Overall Construction Schedule	54
Graphic 6-1	Week 2, Total Peak Week excerpt from network diagram	67
Graphic 6-2	Total vehicles on a week-by-week basis	67
Graphic 6-3	Impact Assessment based on Total peak week	67
Graphic 6-4	Impact Assessment based on HGV peak week	68

List of Annexes

Annex A	Traffic Calculations
Annex B	Figures Figure 23.2.1 Onshore route Temporary Construction Compound (TCC) Sections and accesses from public highways
Annex C	Construction Traffic Peak Movements



Page intentionally blank

Executive Summary

This Traffic Generation Technical Note summarises the methodology used to calculate the traffic generation of the Proposed Development. It includes a summary of the inputs relating to the construction methodology and programme, as well as around routeing of vehicles. This should be read in conjunction with **Chapter 23: Transport, Volume 2** of the **Environmental Statement (ES) [APP-064]** and **Chapter 32:ES Addendum** of the ES (**Document Reference 6.2.23**).



Page intentionally blank

1. Introduction

1.1 Overview

- 1.1.1 This Traffic Generation Technical Note (TGTN) outlines the traffic data generation process for the Rampion 2 (the 'Proposed Development') covering the onshore elements of the Proposed Development including the landfall, onshore cable corridor, temporary construction compounds (TCCs), the onshore substation at Oakendene and the existing National Grid substation extension at Bolney.
- 1.1.2 This TGTN covers the construction, operation and maintenance and decommissioning phases of the Proposed Development.
- 1.1.3 The impacts of traffic are covered separately, in **Chapter 23: Transport, Volume 2** of the Environmental Statement (ES) **[APP-064]** and in **Chapter 32: ES Addendum** of the ES (Document Reference: 6.2.32), while measures to mitigate the impacts of construction traffic, construction workforce, operational traffic generation, abnormal loads and on public rights of way are covered respectively in the:
- **Outline Operational Travel Plan (OTP)** (Document Reference: 7.5);
 - **Outline Construction Traffic Management Plan (CTMP)** (Document Reference: 7.6);
 - **Outline Construction Workforce Travel Plan (CWTP)** (Document Reference: 7.7);
 - **Outline Public Rights of Way Management Plan (PRoWMP)** (Document Reference: 7.8); and
 - **Appendix 23.1: Abnormal Indivisible Loads Assessment** of **Chapter 23: Transport, Volume 2** of the ES **[APP-064]**.

1.2 Context

- 1.1.4 This TGTN is an update to the version that was submitted at Deadline 5 **[REP5-060]**.
- 1.1.5 The following updates were made at Deadline 5::
- **Section 3** – Existing Transport Network:
 - ▶ Baseline Traffic flows updated for Kent Street to reflect traffic survey data contained in the Enso Energy Kent Street Battery Energy Storage System Construction Traffic Management Plan (CTMP) (Planning Application Ref: DC/24/0054).
 - **Section 4** - Proposed Development:
 - ▶ Updates to ensure consistency between DCO application documents on anticipated construction programme.

- **Section 5 - Key Construction Traffic Assumptions:**
 - ▶ Updates to text on construction programme to ensure consistency between DCO application documents.
- **Section 6 - Construction traffic generation:**
 - ▶ **Table 6-8** updated to provide corrections to peak week total construction traffic flows at each access junction.
 - ▶ **Table 6-9** updated to provide corrections to peak week traffic flows on Michelgrove Lane and Kent Street.
 - ▶ Provision of further details of peak periods of construction traffic flows at each access provided in **Annex C**.

1.1.6 The following updates have been made at Deadline 6:

- **Section 3 – Existing Transport Network:**
 - ▶ References to baseline traffic flows for Kent Street and Michelgrove Lane have been updated to reflect traffic surveys completed between 08 and 14 May 2024.

1.2 Structure of this Appendix:

1.2.1 The remainder of this Appendix is structured as follows:

- **Section 2: Relevant legislation, policy and other information and guidance;**
- **Section 3: Existing transport network;**
- **Section 4: Proposed Development;**
- **Section 5: Key Construction traffic Assumptions;**
- **Section 6: Construction traffic generation;**
- **Section 7: Operation and Maintenance traffic generation;**
- **Section 8: Decommissioning traffic generation;**
- **Section 9: Glossary of terms and abbreviations;** and
- **Section 10: References.**

2. Relevant legislation, policy and other information and guidance

2.1 Introduction

2.1.1 This assessment has been undertaken in accordance with relevant transport related planning policy, legislation and guidance at the national, regional and local level.

2.2 National planning policy

2.2.1 **Table 2-1** lists the national planning policy relevant to this TGTN.

Table 2-1 National planning policy relevant to transport

Policy description	How and where considered in this document
The Overarching National Policy Statement for Energy (EN-1) (DECC, 2011)	
<p>Paragraph 5.13.1 states “<i>The transport of materials, goods and personnel to and from a development during all project phases can have a variety of impacts on the surrounding transport infrastructure and potentially on connecting transport networks, for example through increased congestion. Impacts may include economic, social and environmental effects. Environmental impacts may result particularly from increases in noise and emissions from road transport. Disturbance caused by traffic and abnormal loads generated during the construction phase will depend on the scale and type of the proposal.</i>”</p>	<p>The transport Study Area (shown in Figure 7.6.3 of the CTMP (Document Reference: 7.6) has been established through discussions with the relevant Highway Authorities. The Outline Construction Traffic Management Plan (CTMP) (Document Reference: 7.6), Outline Public Rights of Way Management Plan (PRoWMP) (Document Reference: 7.8), and Appendix 23.1: Abnormal Indivisible Loads assessment, Volume 4 of the ES (Document Reference: 6.4.23.1) are also submitted as part of the DCO Application. These documents deal with other impacts and measures of the Proposed Development with respect to transport.</p>
<p>Paragraph 5.13.2 states “<i>The consideration and mitigation of transport impacts is an essential part of Government’s wider policy objectives for sustainable development as set out in Section 2.2 of this NPS</i>”</p>	<p>Section 23.9 to 23.11 of Chapter 23: Transport, Volume 2 of the ES [APP-064] identifies possible transport impacts and ways to mitigate them. The environmental measures to mitigate these impacts are embedded into the design.</p>

Policy description	How and where considered in this document
<p>Paragraph 5.13.3 states “If a project is likely to have significant transport implications, the applicant’s ES (see Section 4.2) should include a transport assessment, using the NATA/WebTAG methodology stipulated in Department for Transport guidance, or any successor to such methodology. Applicants should consult the Highways Agency and Highways Authorities as appropriate on the assessment and mitigation”</p>	<p>This TGTN has been prepared and submitted with the DCO Application in accordance with guidance and best practice and its scope has been discussed with the relevant Highway Authorities including National Highways.</p>
<p>Paragraph 5.13.4 states “Where appropriate, the applicant should prepare a travel plan including demand management measures to mitigate transport impacts. The applicant should also provide details of proposed measures to improve access by public transport, walking and cycling, to reduce the need for parking associated with the proposal and to mitigate transport impacts.”</p>	<p>Chapter 23: Transport, Volume 2 of the ES [APP-064] identifies the highway links which may be subject to possible significant transport effects and any environmental measures to mitigate these transport effects.</p>
<p>Paragraph 5.13.5 states “If additional transport infrastructure is proposed, applicants should discuss with network providers the possibility of co-funding by Government for any third-party benefits. Guidance has been issued in England which explains the circumstances where this may be possible, although the Government cannot guarantee in advance that funding will be available for any given uncommitted scheme at any specified time”</p>	<p>Where appropriate, it is expected that construction worker movements by sustainable means will be facilitated and encouraged. However, it is recognised that the linear nature of the works, the absence of a fixed permanent work site along the Rampion 2 onshore temporary onshore cable corridor and the rural nature of much of the corridor may make it difficult to implement a standard construction travel plan. Many of the accesses are not adjacent to sustainable links such as bus stops and rail lines and the nature of the work means that staff traveling to site need to take equipment and work materials which necessitates the use of vans.</p>
<p>Paragraph 5.13.11 states “The IPC [Planning Inspectorate] may attach requirements to a consent where</p>	<p>Additional transport infrastructure is limited to the provision of a number of mostly temporary construction accesses along the onshore cable corridor. Accesses will be removed and the land reinstated following completion. The Outline CTMP (Document Reference: 7.6) provides further details on access and is submitted as part of the DCO Application.</p>
<p>Paragraph 5.13.11 states “The IPC [Planning Inspectorate] may attach requirements to a consent where</p>	<p>Proposed heavy goods vehicle (HGV) routes are identified and restrictions on HGV timing are proposed to avoid adverse effects on sensitive receptors, particularly schools as</p>

Policy description	How and where considered in this document
<p><i>there is likely to be substantial HGV traffic that:</i></p> <ul style="list-style-type: none"> • <i>Control numbers of HGV movements to and from the site in a specified period during its construction and possibly on the routing of such movements;</i> • <i>Make sufficient provision for HGV parking, either on the site or at dedicated facilities elsewhere, to avoid ‘overspill’ parking on public roads, prolonged queuing on approach roads and uncontrolled on-street HGV parking in normal operating conditions; and</i> • <i>Ensure satisfactory arrangements for reasonably foreseeable abnormal disruption, in consultation with network providers and the responsible police force”</i> 	<p>set out within the Outline CTMP (Document Reference: 7.6). The design of the construction works will avoid the risk of HGV parking on the surrounding highway. The transport of AILs has been subject to necessary assessment within Appendix 23.1: Abnormal Indivisible Loads Assessment, Volume 4 of the ES (Document Reference: 6.4.23.1) and is expected to cause minimal disruption.</p>

Overarching National Policy Statement for Energy (EN-1, March 2023 (DESNZ, 2023a)

NPS EN-1 (2023) contains the generic requirements for the assessment of impacts arising from traffic associated with design, construction and operation of renewable energy infrastructure. Requirements not previously set out in the NPS EN-1 (2011) are set out below:

Paragraph 5.14.7: The applicant should also provide details of proposed measures to improve access by active, public and shared transport to:

- ***reduce the need for parking associated with the proposal;***
- ***contribute to decarbonisation of the transport network;***
- ***reduce the need to travel; and***

Where appropriate, it is expected that movement by sustainable means will be facilitated and encouraged. Sustainable links such as bus stops and rail lines are discussed in the **Outline Construction Workforce Travel Plan (CWTP) [APP-229]** and **Outline Operational Travel Plan [APP-227]**.

Policy description	How and where considered in this document
<p>• secure behavioural change and modal shift through an offer of genuine modal choice and to mitigate transport impacts.”</p>	<p>The objectives of the Delivery Management System are to minimise the number of construction vehicles on the road and ensure construction vehicles do not exceed any agreed restrictions, for example peak period traveling through certain towns / villages / junctions. This is included in the Outline Construction Traffic Management Plan (CTMP) [APP-228].</p>
<p>Paragraph 5.14.8: “The assessment should also consider any possible disruption to services and infrastructure (such as road, rail and airports).”</p>	<p>Trip consolidation and other demand management measures will be implemented are discussed in the Outline Construction Workforce Travel Plan (CWTP) [APP-229] and Outline Operational Travel Plan [APP-227].</p>
<p>Paragraph 5.14.11: “Where mitigation is needed, possible demand management measures must be considered. This could include identifying opportunities to:</p> <ul style="list-style-type: none"> • reduce the need to travel by consolidating trips, • locate development in areas already accessible by active travel and public transport, • provide opportunities for shared mobility, • re-mode by shifting travel to a sustainable mode that is more beneficial to the network, • retime travel outside of the known peak times, • reroute to use parts of the network that are less busy.” 	<p>Trip consolidation, sustainable travel and other demand management measures are discussed in the Outline Construction Workforce Travel Plan (CWTP) [APP-229] and Outline Operational Travel Plan [APP-227]. No new operational road infrastructure is proposed, however accesses and car parks are proposed as part of the Proposed Development.</p>
<p>Paragraph 5.14.12: “If feasible and operationally reasonable, such mitigation should be required, before considering requirements for the provision of new inland transport infrastructure to deal with remaining transport impacts. All stages of the project should support and encourage a modal shift of freight from road to more environmentally sustainable alternatives, such as rail, cargo bike, maritime and inland</p>	

Policy description	How and where considered in this document
<p><i>waterways, as well as making appropriate provision for and infrastructure needed to support the use of alternative fuels including charging for electric vehicles.”</i></p>	
<p>Paragraph 5.14.13: “Regard should always be given to the needs of freight at all stages in the construction and operation of the development including the need to provide appropriate facilities for HGV drivers as appropriate.”</p>	<p>The needs of freight traffic is considered within the Outline Code of Construction Practice (CoCP) [APP-224].</p>
<p>Paragraph 5.14.16: “Applicants should consider the DfT policy guidance “Water Preferred Policy Guidelines for the movement of abnormal indivisible loads” when preparing their application.”</p>	<p>The transport of abnormal indivisible loads (AIL) has been subject to assessment within the Appendix 23.1: Abnormal Indivisible Load assessment, Volume 4 of the ES [APP-196] and is expected to result in minimal disruption.</p>
<p>National Planning Policy Framework (NPPF) (Ministry of Housing, Communities and Local Government, last updated 20 December 2023)</p>	
<p>The NPPF is the primary source of national planning guidance in England.</p>	<p>Whilst the NPPF is not directly applicable to Nationally Significant Infrastructure Projects (NSIPs), it provides context to the TGTN as well as Chapter 23: Transport, Volume 2 of the ES [APP-064] (Document Reference: 6.2.23).</p>
<p>Paragraph 115 of the NPPF states that “development should only be prevented or refused on highways grounds if there would be an unacceptable impact on highway safety, or the residual cumulative impacts on the road network would be severe.”</p>	<p>Chapter 23: Transport, Volume 2 of the ES (Document Reference: 6.2.23), sets out the results of the assessment of traffic effects including highways safety (including accident assessment).</p>
<p>Paragraph 117 of the NPPF states that “all developments that will generate significant amounts of movement should be required to provide a travel plan, and the application should be supported by a</p>	<p>This TGTN has been developed with reference to the criteria in Paragraph 113, the opportunities for sustainable transport, access and road safety, and the need for any transport improvements.</p>

Policy description	How and where considered in this document
<p><i>transport statement or transport assessment so that the likely impacts of the proposal can be assessed.”</i></p>	<p>For understanding transport impacts, this TGTN is supported by the Outline CTMP (Document Reference: 7.6), Outline CWTP (Document Reference: 7.7), Outline PRowMP (Document Reference: 7.8) and Appendix 23.1: Abnormal Indivisible Loads assessment of the ES (Document Reference: 6.4.23.1).</p>
<p>The document sets out that the Transport Statement (TS)/TA should account for:</p> <ul style="list-style-type: none"> • the opportunities for sustainable transport modes have been taken up depending on the nature and location of the site, to reduce the need for major transport infrastructure; • safe and suitable access to the site can be achieved for all people; and • improvements can be undertaken within the transport network that cost effectively limit the significant impacts of the development. Development should only be prevented or refused on transport grounds where the residual cumulative impacts of development. 	

2.2.2 Table 2-2 lists the local planning policy relevant to the assessment of the effects on transport receptors.

Table 2-2 Local transport / planning policy relevant to transport

Policy description	Relevance to assessment
<p>West Sussex Transport Plan 2022-36 (West Sussex County Council, 2022)</p>	
<p>4.23-4.25 and 6.4: Walking. The policy aims to maintain the existing pedestrian provision in West Sussex, including PRow provision, and, where possible provide new infrastructure to create new connections and routes for pedestrians particularly for leisure. More information is also included</p>	<p>The construction of the onshore cable has the potential to temporarily affect the Public Right of Way (PRow) infrastructure in West Sussex. The Outline PRowMP (Document Reference: 7.8) outlines all PRow effects and environmental measures proposed.</p>

Policy description	Relevance to assessment
<p>on PRoWs in the WSCC Rights of Way Management Plan 2018-2028.</p>	
<p>4.26-4.29 and 6.4: Cycling. This policy aims to protect the existing cycling provision and promote cycling as a form of sustainable transport. It also identifies a requirement to construct and improve cycling infrastructure to connect local cycle networks in line with the LCWIPs.</p>	<p>The construction of the onshore cable has the potential to temporarily affect local and nationally strategic cycle routes in West Sussex. A review of the local cycle routes has been undertaken within this document in Section 3 and sets out that impacts on National Cycle Network (NCN) routes will not be significant.</p>
<p>4.33-4.39 and 6.12: Shared Transport Services. This policy proposes a range of measures to promote and improve public transport in West Sussex. Measures include the maintenance of public transport to a good standard and the provision of new infrastructure – such as bus lanes- to improve the existing provision where this is possible.</p>	<p>The construction of the onshore cable has the potential to temporarily affect local bus routes in West Sussex. A review of local bus routes is included in Section 3.</p>
<p>4.64-4.66 and 6.25: Freight. This policy sets out the measures which are to be used to manage the movement of freight during the plan period. The policy identifies measures to be used, including a lorry route network around West Sussex and investment into major infrastructure improvements on the A27.</p>	<p>The policy and HGV route network have been considered when identifying construction HGV routes associated with the Proposed Development set out in Section 4. The HGV access strategy avoids Findon Valley, a key route restriction within the Freight Movement and Management Plan.</p>
<p>Draft Horsham District Local Plan 2019-2036 (Horsham District Local Council, 2019)</p>	
<p>Strategic policy 41 – Infrastructure Provision. This policy states that development will only be supported if local infrastructure has adequate capacity to support the development. Suitable mitigation should be proposed where local infrastructure does not have the</p>	<p>Consideration of transport effects and requirements for environmental measures. Chapter 23: Transport, Volume 2 of the ES (Document Reference: 6.2.23) sets out the results of the assessment of the traffic effects on local and strategic highways links.</p>

Policy description	Relevance to assessment
<p>capacity to accommodate development.</p> <p>Strategic policy 42 – Sustainable Transport. This policy sets out the conditions in which development will be supported for sustainable transport. The policy states “development will be supported if it:</p> <p><i>Provides safe and suitable access for all vehicles, pedestrians, cyclists, horse riders, public transport and the delivery of goods. Minimises the distance people need to travel and minimises conflicts between traffic, cyclists and pedestrians. Prioritises and provides safe and accessible walking and cycling routes and is integrated with the wider network of routes, including public rights of way and cycle paths. Includes opportunities for sustainable transport which reduce the need for major infrastructure and cut carbon emissions. Develops innovative and adaptable approaches to public transport in the rural areas of the District. Maintains and improves the existing transport system (pedestrian, cycle, rail and road). Is accompanied by an agreed Green Travel Plan where it is necessary to minimise a potentially significant impact of the development of the wider area, or as a result of needing to address an existing local traffic problem.”</i></p>	<p>The construction of the onshore cable has the potential to temporarily affect PRow, local bus routes and cycle routes in Horsham.</p> <p>The Outline PRowMP (Document Reference: 7.8) outlines all PRow effects and environmental measures proposed.</p> <p>A review of the local cycle routes has been undertaken within the Chapter 23: Transport, Volume 2 of the ES (Document Reference: 6.2.23) which sets out the potential effects on NCN routes.</p> <p>A review of local bus routes has been undertaken within the Chapter 23: Transport, Volume 2 of the ES (Document Reference: 6.2.23) which sets out the potential effects on bus routes.</p>
<p>Mid Sussex District Plan 2014-2031 (Mid Sussex District Council, 2018)</p> <p>DP20: Securing Infrastructure. This policy requires development to be provided with necessary</p>	<p>Additional transport infrastructure is limited to the provision of a number of mostly temporary construction accesses along the Rampion 2 onshore temporary cable corridor. Accesses</p>

Policy description	Relevance to assessment
<p>infrastructure such as efficient and sustainable transport networks.</p>	<p>will be removed where appropriate and where agreed with landowners and the land reinstated when the Rampion 2 onshore cable construction is finished. Where accesses are not removed, they will remain in-situ, for example, the access to the onshore landfill site and onshore substation. The Outline CTMP (Document Reference: 7.6) outlines further details on access.</p>
<p>DP21: Transport. This policy requires developments, depending on their size or impact to prepare a Transport Statement or Transport Assessment to be submitted with the planning application. The policy also requires submission of a travel plan statement or full travel plan alongside the transport statement or transport assessment which will be submitted with the planning application.</p>	<p>This TGTN is provided as part of the DCO Application. The assessment presented is a link based environmental assessment and is supported by the Outline CTMP (Document Reference: 7.6), Outline PRowMP (Document Reference: 7.8) and Appendix 23.1: Abnormal Indivisible Load assessment of the ES (Document Reference: 6.2.23.1). Outline documents were presented at PEIR stage and further discussions with relevant highways authority have been undertaken to define if there is a significant effect or not.</p>
<p>DP22: Rights of Way and other Recreational Routes. This policy aims to protect existing rights of way, cycle and recreational routes from any adverse effects that might come from development. It also states that where a route is likely to be affected an alternative must be provided which is equivalent in value to the route affected.</p>	<p>The protection of PRowWs, including recreational routes and National Trails has been included within the Outline PRowMP (Document Reference: 7.8).</p>
<p>Worthing Local Plan 2020 – 2036 (Worthing Borough Council, 2023)</p>	
<p>DM15 Sustainable Transport and Active Travel. The policy sets out that Worthing Borough Council will support development which encourages use of public and sustainable transport and reduces the number of car journeys. Where development is likely to generate demand for travel or have other implications it is required to be supported by a Transport Statement or Assessment and a sustainable</p>	<p>Chapter 23: Transport, Volume 2 of the ES (Document Reference: 6.2.23) and the Outline CTMP (Document Reference: 7.6) outline the proposed HGV access strategy and environmental measures and routes that have been applied to mitigate impacts of the construction phase of the Proposed Development.</p>

Policy description	Relevance to assessment
<p>travel plan. The policy further states that it will “<i>support measures that promote improved accessibility, create safer roads, reduce the environmental impact of traffic movements, enhance the pedestrian environment, or facilitate highway improvements</i>”. In particular reference is made to managing the impact of HGV movements and implementing measures where this may be appropriate.</p>	
<p>West Sussex Walking and Cycling 2016 – 2026 (West Sussex County Council, 2020a)</p>	
<p>The West Sussex Walking and Cycling strategy is a document that sets out the aims and objectives for walking and cycling during the strategy period (2016-2026) and sets out guidance and information for developers.</p>	<p>The Outline PRowMP (Document Reference: 7.8), outlines all PRow impacts and environmental measures proposed.</p>

2.3 Other relevant information and guidance

The Strategic Road Network and the Delivery of Sustainable Development Guidance

- 2.3.1 The Department for Transport (DfT) (2022) Circular 012022 ‘*The Strategic Road Network and the Delivery of Sustainable Development*’ outlines the methods in which the National Highways (NH) (formally National Highways) will engage with developers and communities to deliver sustainable development and consequently economic growth, whilst safeguarding the primary function and purpose of the Strategic Road Network (SRN).
- 2.3.2 Paragraph 55 outlines under ‘Environmental assessments’:
- “The company will engage in the relevant screening or scoping process where a potential impact on the SRN is identified. Environmental assessments must be comprehensive enough to establish the likely impacts on air quality, light pollution and noise arising from traffic generated by a development, along with the impacts from any proposed works to the SRN and identify measures to mitigate these impacts. Requirements and advice for undertaking environmental assessments in respect of transport impacts can be found in the DMRB.”*
- 2.3.3 Paragraph 65 to 69 outlines access requirements relating to on-shore wind turbines:

“The promoter of a wind turbine development must identify any impacts on the operation of the SRN from the construction, operation and de-commissioning stages and identify measures to mitigate these impacts. Swept path analyses must be provided for any abnormal load deliveries to the site via the SRN.

Access to the site for construction, maintenance and de-commissioning should be obtained from the local road network. A direct connection to the SRN will only be permitted in exceptional circumstances.”

- 2.3.4 Within the transport Study Area (outlined in **Figure 7.6.3** in the **Outline Construction Traffic Management Plan (CTMP)** (Document Reference: 7.6), the SRN managed by NH includes the A27 and A23. The requirements of Circular 01/2022 are therefore addressed further within this TGTN.

Page intentionally blank

3. Existing Transport Network

3.1 Study Area 1 – onshore

- 3.1.1 This Section provides a description of the baseline conditions of the local and strategic roads which are proposed to be used for access to the onshore elements of the Proposed Development as well as the local PRoW, cycle routes and sustainable travel routes. **Figure 23.1, Volume 3** of the ES (Document Reference: 6.3.23) identifies the roads that have been included in this section.
- 3.1.2 **Table 3-1** sets out a high-level review of the Main “A” and “B” Roads included within Study Area 1 and more details on these are presented in the following section.

Table 3-1 A/B roads within Study Area 1

Type of road	Road name
A Roads	A259, A284, A27, A24, A284, A283, A281, A272, A23
B Roads	B2139, B2135, B2116, B2118

Strategic Road Network

A23

- 3.1.3 The A23 routes from the M23 south of Crawley to the A27 on the northern periphery of Brighton. For much of its length, the A23 is a dual carriageway subject to the national speed limit¹. Within Study Area 1, the A23 has junctions with two major roads, the A272 and the A27 as follows:
- the junction with the A272 is located east of Bolney and comprises grade separated roundabout junctions located either side of the A23 alignment which connect to the A23 with on/off slips; and
 - the junction with the A27 is located on the northern periphery of Brighton and comprises a grade separated bell junction with on/off slips which connects to a separate roundabout junction with the A23.

A27

- 3.1.4 The section of the A27 that is managed by National Highways (NH) routes between Pevensey in East Sussex to Cosham, Portsmouth where the A27 becomes the M27. The A27 connects numerous coastal towns along the south coast as well as connecting the cities of Portsmouth and Brighton. Road design

¹ 70mph for cars and motorcycles, 60mph for all other vehicles

standards vary along the A27, however, for most of its length the A27 is a dual carriageway subject to the national speed limit.

Local Highway Network

A24

- 3.1.5 The A24 routes between Worthing on the south coast and London, and routes via towns including Horsham and Leatherhead. Within Study Area 1, the A24 routes through both urban and rural settings. In rural areas the A24 is typically a dual carriageway and is subject to the national speed limit. In urban areas the A24 routes through both residential and commercial areas, and numerous residential and commercial properties front onto the road and there are a number of pedestrian crossing points.

A272

- 3.1.6 Within Study Area 1, the A272 routes east/west between the A24 and the A23. The A272 intersects the A24 via a staggered crossroad and junctions with the A23 are via two grade separated roundabouts which connect to the A23 by on/off slips. The A272 is a predominantly a single carriageway rural road throughout Study Area 1. The speed limit varies between national speed limit (60mph for cars and motorcycles) and 50mph depending on local constraints. A section of the A272 through Cowfold is subject to a 30mph speed limit as the road passes through a village setting. Pedestrian footways are provided, and residential properties front onto the A272 throughout Cowfold.

A2037

- 3.1.7 The A2037 routes north / south between the A283 and the A281. The road intersects with the A281 at a roundabout in the south of Henfield. The A2037 is a predominantly single lane, two-way carriageway rural through road and is subject to the national speed limit. It intersects with the A283 at a roundabout, south of Steyning. The road has limited pedestrian footways including through Henfield and Oreham Common, where some residential properties front onto the road. There is very limited pedestrian crossing points.

A280 Long Furlong

- 3.1.8 The A280 Long Furlong provides a connection between the A24 at Findon and the A27 south of the village of Clapham. The A280 is a single carriageway road which is predominantly subject to the national speed limit through a rural setting. A small section of the A280 through Clapham Village is subject to a 40mph speed limit, and a signal controlled crossing is provided adjacent to the local primary school.

A281

- 3.1.9 The A281 routes between Guildford and the A23 north of Brighton, the road connects multiple towns and villages along its routes including Horsham and Cowfold. Due to the length of the A281 and the numerous settlements that it

passes through the road conditions vary throughout. The A281 within Study Area 1 includes a section from Cowfold via Shermanbury to the A281 junction with the B2116. The A281 through this section is a single carriageway road where the speed limit and other conditions vary depending on location.

- 3.1.10 Through Cowfold the A281 routes through the centre of the village where commercial properties front onto the road. Pedestrian footways are located on either side of the carriageway within Cowfold centre and on at least one side of the carriageway through the rest of the village. The road is subject to a 30mph speed limit. The A281 connects with the A272 at two mini roundabout junctions within Cowfold centre and a signal controlled pedestrian crossing is provided.
- 3.1.11 Through Shermanbury, the A281 is subject to a 40mph speed limit, and a pedestrian footway is provided on the eastern side of the carriageway. Residential properties/driveways front onto the A281.
- 3.1.12 Between Cowfold and Shermanbury the A281 is rural in nature, no pedestrian infrastructure is provided, and the national speed limit for a single carriageway.
- 3.1.13 The section of the A281 from Henfield to the junction with the B2117 routes through the small village of Woodmancote. The A281 is 30mph through Henfield, and then 40mph past Woodmancote before changing to a national speed for the rest of the route.

A283

- 3.1.14 The A283 provides a connection between the A24 at Washington, West Sussex and the A27 at Shoreham-by-Sea. The A283 is a single carriageway which is subject to 50mph and national speed limits at various points along its route. The A283 passes predominantly through rural areas. In Steyning, the A283 is located largely in a cutting with local roads on overbridges. The A283 joins with the A27 via a grade separated roundabout and on-off slips.

A284

- 3.1.15 The A284 routes between Littlehampton and the A29 west of the village of Houghton. The A281 exists in two sections, from Littlehampton to a junction with the A27 at Crossbush and from a junction with the A27 in Arundel to the A29.
- 3.1.16 The section of the A284 from the A259 in Littlehampton to the A27 at Crossbush is within Study Area 1. This section of the A284 passes through the village of Lyminster and the residential suburb of Wick. In Wick, the A284 routes through a residential area where streetlighting and footways are provided, and residential properties and driveways front onto the A284. The road is subject to a 30mph speed limit.
- 3.1.17 In Lyminster Village, the road is subject to a 30mph speed limit. Pedestrian footways exist throughout the village on at least one side of the carriageway and a small number of residential properties/driveways front onto the A284. North of Lyminster Village, the speed limit increases to 40mph, and a pedestrian footway continues on the western side of the carriageway.

- 3.1.18 The construction of the Lyminster Bypass, which is expected to be officially designated as the A284 upon completion, will be a significant development in the road infrastructure. The Lyminster Bypass will serve to reduce the volume of traffic passing through Lyminster and reduce the impacts on local receptors arising as a result.

A259

- 3.1.19 The A259 routes along the south coast of England between Havant in Hampshire and Folkestone in Kent. Within Study Area 1, the A259 travels between a roundabout junction with Ford Lane at Climping to a roundabout junction with the B2187 at Toddington.
- 3.1.20 Between Climping and the junction with the B2187 at Littlehampton (Bridge Road roundabout), the road is a single carriageway which is subject to a 40mph speed limit west of the Ferry Road junction and the national speed limit east of the junction. A shared footway/cycleway is provided on the northern side of the carriageway.
- 3.1.21 Between Bridge Road roundabout and the junction with the A284 (Wick roundabout), the road is subject to the national speed limit and a shared cycleway/footway exists on the northern side of the carriageway between the signal controlled junction with Benjamin Grays Drive and the priority junction with New Courtwick Lane. Between Wick roundabout and the roundabout junction with the B2187 at Toddington the speed limit is reduced to 40mph, and pedestrian footways exist on both sides of the carriageway. Residential properties front onto the carriageway through this section.

B2116

- 3.1.22 The B2116 routes between the A281 north of Henfield to the B2118 at Aldbourne. The B2116 is a single carriageway which predominantly passes through a rural area. The speed limit varies between 30mph, 40mph and the national speed limit along the B2118 depending on local constraints. Throughout Aldbourne, the road is subject to a 30mph speed limit and pedestrian footways are provided and residential properties/driveways front onto the road.

B2117

- 3.1.23 The B2117 is a single carriageway road which passes between the A281 and Hurstpierpoint village. Within the short section of the road included in Study Area 1, the road joins the B2118 at a priority junction and the A23 at two priority junctions which serve as southbound on and northbound off slips to the grade separated A23. The B2117 is rural in nature between these junctions and is subject to the national speed limit.

B2118

- 3.1.24 The B2118 routes between the B2117 at Muddleswood and the A23 north of Sayers Common. The B2118 is a single carriageway and is subject to the national speed limit for much of its route.

3.1.25 Through the village of Aldbourne, the road is subject to a 40mph speed limit. A pedestrian footway is provided on the eastern side of the carriageway and residential properties/driveways front onto the road.

3.1.26 Through the village of Sayers Common, the B2118 is subject to a 30mph speed limit and pedestrian footways are provided on both sides of the carriageway. Residential properties/driveways front onto the B2118 and there is a mini-roundabout junction with Reeds Lane in the centre of the village.

B2135

3.1.27 The B2135 is a rural B-road serving the village of Partridge Green in Sussex. It is subject to the national speed limit for most of its route. It starts on the A283 at the northern end of the Steyning bypass. It heads north and, although quite wide the route is windy before straightening out, before entering the small village of Ashurst. Through the village of Ashurst the road is subject to a 30mph speed limit. The road then heads into Partridge Green (also 30mph speed limit) where it meets the B2116, and continues through the village, after which it turns north-west towards the A24.

B2139

3.1.28 The B2139 is a rural B-road which runs through Houghton, Amberly and Storrington in West Sussex. Much of the route is subject to the national speed limit, although Houghton and Storrington have a 30mph limit and Amberly is subject to a 40mph speed limit. The B2139 begins at Whiteways Lodge Roundabout with the A29 and the A284, and then runs northeast until Storrington, where it meets Pulborough Road (A283). The road is crossed by no other major roads, only residential streets when routing through villages. It is also the only access to Amberly Train Station.

Ferry Road

3.1.29 Ferry Road is a single carriageway road which routes between the A259 and the River Arun in Littlehampton. From a priority junction with the A259, the road routes through a rural area where a national speed limit applies, and narrow pedestrian footway is provided on the northern side. The road provides access to the Marina, Mobile Home Park and some other industrial buildings. Ferry Road is also the National Cycle Network Route 2 (NCN 2) providing access to Littlehampton station via the Littlehampton Harbour Bridge.

Ford Road

3.1.30 Ford Road is a single carriageway road which routes between the A27 in Arundel and Church Lane in Climping. From a roundabout junction with the A27 to the edge of Arundel, the road passes through a residential area where a 30mph speed limit applies and pedestrian footways are provided. South of Arundel the road is rural in nature and the national speed limit applies. Adjacent to Ford station, Ford Road crosses a railway line at a level crossing. North of the level crossing a 40mph speed limit is applied to Ford Road which continues for its remaining route to Church Lane in Climping. Between Ford Station and Climping a pedestrian footway exists on the western side of the carriageway.

Church Lane

- 3.1.31 Church Lane is a single carriageway road which routes between Ford Road in Climping to a roundabout junction with the A259 south of Climping. The road is subject to a 40mph speed limit, and a pedestrian footway is provided on the eastern side of the carriageway. A small number of residential properties front onto Church Lane in Climping.

Water Lane

- 3.1.32 Water Lane is single carriageway rural road which routes between the A283 and Hole Street in Winston. Water Lane is subject to the national speed limit between the junction with the A283 and the periphery of Winston Village. In Winston Village, Water Lane is subject to a 40mph speed limit, and a pedestrian footway is provided on the western side of the carriageway.

Kent Street

- 3.1.33 Kent Street is a single carriageway rural road which passes between the A272 and Wineham Lane and is subject to the national speed limit. There are no pedestrian footways on this rural road.

Wineham Lane

- 3.1.34 Wineham Lane is a single carriageway rural road which connects the village of Wineham to the A272 to the north and the B2116 to the south. Wineham Lane is subject to the national speed limit for all sections outside Wineham. Throughout Wineham, it is subject to a 40mph speed limit and residential/rural properties and driveways front onto the road.

Michelgrove Lane

- 3.1.35 Michelgrove Lane is a single carriageway rural road which provides access to a few residential properties. Michelgrove Lane is subject to the national speed limit, albeit this would be difficult to achieve given the nature of the road.

Baseline traffic flows

- 3.1.36 It has been agreed with WSCC highways officers that baseline traffic flows can be derived from existing traffic counts, most of which are taken from either permanent count locations maintained by WSCC/DfT or one-off counts within the WSCC (2020b) online traffic count database. For most locations, this has resulted in the use of data from 2019.
- 3.1.37 Following this approach resulted in a lack of traffic data for one specific location (Ferry Road – Highways Link 1) and also included data from pre-2010 for four other locations - Crossbush Lane (Highways Link 10), A280 Long Furlong (Highways Link 15), A283 East of Washington (Highways Link 17) and B2188 Sayers Common (Highways Link 29). The absence of current traffic data for these locations made it difficult to determine the baseline conditions. Therefore the assessment was informed by new traffic counts undertaken in mid-2022 at these five locations and as such were available for use in this TGTN.

- 3.1.38 In locations where the available traffic data is older than 2022, it was agreed with WSCC that no additional traffic counts were required to be undertaken as the counts from 2017-2019 were considered to still be representative, given the low level of additional traffic forecast in comparison to existing flows on the roads as indicated by the previous counts.
- 3.1.39 In agreement with WSCC, growth rates have been derived from the DfT's TEMPro 7.2. Growth rates for HGVs have been derived from the DfT (2020) National Traffic Statistics. A base year of 2021 has been used to growth up the available data for the baseline traffic counts.
- 3.1.40 Growth rates from TEMPro have been based on two areas: Arun for the south west sections (code, E41000245) and Horsham for the remainder of Study Area 1 (code E41000248).
- 3.1.41 The TEMPro growth rates are as follows:
- 2012 – 2021 – Arun – 1.1387 – Horsham – 1.1468;
 - 2013 – 2021 – Arun – 1.1232 – Horsham – 1.1292;
 - 2017 - 2021 – Arun – 1.0607 – Horsham – 1.0608;
 - 2018 - 2021 - Arun – 1.0454 – Horsham – 1.0454; and
 - 2019 – 2021 – Arun – 1.0305 – Horsham – 1.0306.
- 3.1.42 HGV growth has been based on the DfT (2021) publication '*TRA2501c - Road traffic (vehicle miles) by vehicle type in Great Britain*'. Table TRA2501c presents national data of the yearly change in vehicle traffic for total vehicles, car, light commercial vehicles and HGVs.
- 3.1.43 Based on Table TRA2501c, annual growth factors for HGVs have been derived as follows:
- the changes in HGV traffic flows between 2019 (last reliable year of data due to the COVID-19 pandemic) and the base year of 2021 has been calculated;
 - the growth factor from 2018 to 2019 was 0.38%;
 - estimated growth between 2019 and 2021 is assumed as 0.38% per annum, or 0.76% over the two years; and
 - the growth for 2019 – 2021 (0.76% has been added to the growth from the historic count year to 2019 to provide for a growth from historic count year to 2021).
- 3.1.44 It should be noted the traffic count for A283 (East of A24) is dated 2005. As TEMPro does not extend as far back as 2005, an alternative method based on the DfT statistics has been used as discussed and agreed with WSCC.
- 3.1.45 The calculations above presented the following growth rates for HGVs:
- 2005 – 2021 - 0.9755;
 - 2012 – 2021 – 1.0778;
 - 2013 – 2021 – 1.10180;

- 2017 – 2021 - 1.0270;
- 2018 – 2021 - 1.0160; and
- 2019 – 2021 – 1.00750.

3.1.46 For locations where total vehicle traffic data was extracted from existing counts, but where there were no HGV breakdowns in these counts, an HGV percentage was required to develop an HGV traffic flow at these locations. There were three locations where this was required;

- Highways Link 10 – Crossbush Lane;
- Highways Link 17 – A283 East of A24; and
- Highways Link 29 – B2188, Sayers Common.

3.1.47 At all three of these locations, the historic traffic data only present a breakdown of total vehicles. To estimate a likely HGV percentage on these highways links, reference has been made to adjacent historic traffic counts as follows:

- Highways Link 10 – Crossbush Lane – 2% HGVs based on Highways Link 8 data;
- Highways Link 17 – A283 East of A24 – 3.4% HGVs based on Highways Link 16 data; and
- Highways Link 29 – B2188, Sayers Common – 4.7% HGVs based on Highways Link 32 data.

3.1.48 **Table 3-2** sets out the average annual weekday flow (AADF) for the date of survey and the baseline (2021). Figure 32.2 of **Chapter 32: ES Addendum** of the ES (Document Reference: 6.2.32) shows the location of each of these links in relation to their identified receptor.

Table 3-2 2021 baseline traffic data (AADF) – Study Area 1

Highways Link	Historic Traffic Data			2021 Base		
	Total Vehicles	HGVs	Year of Data	Total Vehicles	HGVs	HGV%
1	1925	314	2022	1925	314	16.3%
2	9859	1106	2019	10458	1135	10.9%
3	6025	253	2019	6209	255	4.1%
4	23618	1302	2019	24338	1312	5.4%
5	22400	857	2019	23083	863	3.7%
6	13248	551	2019	13652	555	4.1%

Highways Link	Historic Traffic Data			2021 Base		
	Total Vehicles	HGVs	Year of Data	Total Vehicles	HGVs	HGV%
7	13546	692	2018	13959	698	5.0%
8*	619	12	2019	647	12	1.9%
9	32734	1613	2013	33732	1625	4.8%
10*	736	15	2019	827	16	2.0%
11	31936	1757	2019	32910	1770	5.4%
12	22776	923	2019	23473	930	4.0%
13	30777	1012	2018	31719	1020	3.2%
14	25731	627	2017	26899	637	2.4%
15	16300	949	2019	17291	975	5.6%
16	18580	3653	2022	18580	3653	19.7%
17	21977	750	2005	22649	755	3.3%
18	5001	170	2019	5861	166	2.8%
19	11430	2326	2022	11430	2326	20.3%
20	3444	105	2019	3550	106	3.0%
21	20485	585	2019	21112	589	2.8%
22	35481	1636	2019	36567	1648	4.5%
23	6374	362	2018	6569	364	5.5%
24	7739	341	2019	8090	346	4.3%
25	6081	141	2019	6267	142	2.3%
26	22389	991	2019	23074	998	4.3%
27	16904	745	2019	17421	751	4.3%

Highways Link	Historic Traffic Data			2021 Base		
	Total Vehicles	HGVs	Year of Data	Total Vehicles	HGVs	HGV%
28	853	16	2019	879	16	1.8%
29	16889	724	2019	17406	729	4.2%
30	71894	4024	2012	74094	4054	5.5%
31	6227	293	2019	7141	315	4.4%
32	7356	1497	2022	7356	1497	20.4%
33	3147	149	2019	3243	150	4.6%
34	78611	3118	2019	81016	3141	3.9%
35	65068	2421	2019	67059	2439	3.6%

*Highway Link 8 and 10 will not be used by construction traffic associated with the Proposed Development.

- 3.1.49 For locations where total vehicle data was extracted from existing counts undertaken in 2022, it has been assumed that traffic levels have remained unchanged from 2021. The growth rate between 2021 and 2022 is negligible, and in 2021 traffic flows were also still being affected by COVID-19 pandemic. Consequently the 2022 survey results for the highway links in **Table 3-3** were also assumed to be a reasonable proxy for 2021 baseline in **Table 3-2**.
- 3.1.50 **Table 3-3** sets out the Annual Average Traffic Flows (AATF) for the locations that were surveyed in 2022 since the original PEIR was published.

Table 3-3 Baseline data – 2022 Traffic survey

Highways Link	Light Vehicles (LVs)	Heavy Goods Vehicles (HGVs)	Total Vehicles
1 – Ferry Road	1611	314	1925
15 – A280 Long Furlong	14927	3653	18580
17 – A283 East of the A24	9104	2326	11430
29 – B2188 Sayers Common	5859	1497	7356

- 3.1.51 The following baseline traffic flows have been included in **Table 3-4** below for the new receptor locations. Figure 32.2 of **Chapter 32: ES Addendum** of the ES (Document Reference: 6.2.32) shows the location of each of these links in relation to their identified receptor. This includes traffic survey data collected in May 2024 on Michelgrove Lane (Receptor P) and Kent Street (Receptor U).

Table 3-4 Baseline traffic data for the new receptors (AADF) (Total peak week)

Highways Link	Historical Traffic Data			2021 Base		
	Total Vehicles	HGVs	Year of Data	Total Vehicles	HGVs	% HGVs
A B2139, Coolham Road	8918	422	2012	10227	454	4.4%
B A272, West Chiltington Lane, Pound Lane, Shipley Road	8918	422	2012	10227	454	4.4%
C A272, Cowfold Road	16904	745	2019	17421	751	4.3%
D B2135, Steyning Road, East of Park Lane	4525	20	2017	4800	21	0.4%
E A272, Bolney Road, East of A281, North of Oakfield Road	19786	668	2023	N/A	N/A	N/A
F A272, Cowfold	16889	724	2019	17406	729	4.2%

Highways Link	Historical Traffic Data			2021 Base		
	Total Vehicles	HGVs	Year of Data	Total Vehicles	HGVs	% HGVs
Road West of the A23						
G A281, North of Woodside Close	6081	141	2019	6267	142	2.3%
H B2135 / B2116 High Street, Partridge Green	6374	362	2019	6569	364	5.5%
I A281, Brighton Road, North of Partridge Green Road	7739	341	2018	8090	346	4.3%
J Wineham Lane	853	16	2019	879	16	1.8%
K B2118, East of B2116 Henfield Road	3147	149	2019	3243	150	4.6%
L B2135, North of Spithandle Lane	3444	105	2019	3550	106	3.0%
M A281, High Steet, Henfield	7739	341	2018	8090	346	4.3%

Highways Link	Historical Traffic Data			2021 Base		
	Total Vehicles	HGVs	Year of Data	Total Vehicles	HGVs	% HGVs
N A281, Brighton Road	4963	72	2023	N/A	N/A	N/A
O A283 Storrington Road, Northeast of Sullington Lane	21977	750	2019	22649	755	3.3%
P Michelgrove Lane	377	27	2024	N/A	N/A	N/A
Q A284, Lyminster Road	13546	692	2019	13959	698	5.0%
R Church Lane, North of the A259	9859	1106	2017	10458	1135	10.9%
S Ford Road, Station Road	6025	253	2019	6209	255	4.1%
T Ford Road	6025	253	2019	6209	255	4.1%
U Kent Street	371	77	2024	N/A	N/A	N/A

3.2 Study Area 2 – onshore impacts of offshore works

3.2.1 This section provides a description of the baseline conditions of the local and strategic roads which are proposed to be used for access to the onshore elements of the offshore operation and maintenance phase (access to Port of Newhaven) of the Proposed Development. **Figure 23.6, Volume 3** of the ES (Document Reference: 6.3.23) identifies the roads that have been included in this section.

3.2.2 **Table 3-5** sets out a high-level review of the main “A” and “B” Roads included within Study Area 2 and more details on these are presented in the following section.

Table 3-5 A/B Roads within Study Area 2

Type of Road	Road Name
A Roads	A27, A26, A259
B Roads	B2109

Strategic Road Network

A27

3.2.3 The section of the A27 that is managed by National Highways (NH) routes between Pevensey in East Sussex to Cosham, Portsmouth where the A27 becomes the M27. The A27 connects numerous coastal towns along the south coast as well as connecting the cities of Portsmouth and Brighton. Road design standards vary along the A27, however, for most of its length the A27 is a dual carriageway subject to the national speed limit. Within Study Area 2, the junction with the A26 is located at Beddingham.

Local Highway Network

Beach Road / Clifton Road / Railway Road

3.2.4 Beach Road / Clifton Road / Railway Road is a two lane single carriageway urban road which connects the East Quay of Newhaven Port to the A26/B2109. The road is subject to a 30mph speed limit. In the southern section (Beach Road) the route is industrial in nature but passes through residential areas on the Clifton Road and Railway Road section. The route has footways on both sides and is provided with streetlights.

B2109

3.2.5 The B2109 is a two-lane single carriageway that runs from the A26 south to join the A259, then parallel to the A259, and then south from the A259 west of the overpass near Newhaven Town rail station. In Study Area 2, the B2109 runs between the two junctions at either side of the A259 overpass and is provided with footways, pedestrian crossings (under signal control) and streetlights. The B2109 is subject to a 30mph speed limit. The B2109 also has an at grade signalled rail level crossing to the west of the junction with Railway Road.

A259

- 3.2.6 The A259 routes along the south coast of England between Havant in Hampshire and Folkestone in Kent. Within Study Area 2, the A259 routes Newhaven Town Centre and a junction with McKinley Way.
- 3.2.7 In Study Area 2, the A259 is a two lane single carriageway which for the most part is a flyover between McKinley Way and Newhaven Town Centre. The A259 is subject to a 30mph speed limit and has footways either side of road apart from the flyover section. The A259 also has streetlights and west of the flyover section has a signal-controlled crossing of the River Ouse to accommodate the swing bridge operation.

A26

- 3.2.8 The A26 is a two lane single carriageway in Study Area 2 that links Newhaven to Kent and is a primary route in the south east of England.
- 3.2.9 In Study Area 2, the A26 links to the B2109/A259 in Newhaven and routes north to a roundabout junction with the A27 at Beddingham. The road is subject to the national speed limit (NSL) outside of settlements but reduces to 40mph in South Heighton and 30mph in Newhaven. The A26 has footways and streetlights in the major settlements but is not provided with footways in the rural sections.

McKinley Way (Newhaven Port New Access Road)

- 3.2.10 McKinley Way is a 1.4km two lane single carriageway which runs from a roundabout junction with the A259, via a new intermediate roundabout, to a new roundabout providing access to Newhaven East Quay. The road has footways as well as a segregated cycle track, and the southern end of the road includes a bridge spanning the Newhaven to Seaford railway line and Mill Creek. McKinley Way is subject to a 30mph speed limit.

Baseline traffic flows

- 3.2.11 The approach to the collation of baseline traffic for Study Area 2 is the same as Study Area 1 and historic traffic data has been used, derived from the DfT traffic data.
- 3.2.12 Growth rates for total vehicles have been derived from the DfT's TEMPro 7.2. A base year of 2021 has been used to growth up to for the baseline traffic counts. Growth rates from TEMPro have been based on TEMPro rates for Lewes 008/009 within the database which covers the town of Newhaven. The TEMPro growth rates are as follows:
- 2018 - 2021 - Newhaven – 1.93.
- 3.2.13 HGV growth has been based on the DfT (2021) publication 'TRA2501c - Road traffic (vehicle miles) by vehicle type in Great Britain'. Table TRA2501c presents national data on the yearly change in vehicle traffic for total vehicles, car, light commercial vehicles and HGVs.

- 3.2.14 Based on Table TRA2501c, annual growth factors for HGVs have been derived as follows:
- the change in HGV traffic flows between 2019 (last reliable year of data due to the COVID-19 pandemic) and the base year of 2021 has been calculated;
 - the growth factor for from 2018 to 2019 was 0.38%;
 - estimated growth between 2019 and 2021 is assumed as 0.38% per annum, or 0.76% over the two years; and
 - the growth for 2019 – 2021 (0.76% has been added to the growth from the historic count year to 2019 to provide for a growth from historic count year to 2021).
- 3.2.15 The calculations above presented the following growth rates for HGVs:
- 2019 – 2021 – 1.00750
- 3.2.16 Due to the Newhaven Port New Access Road not yet having been opened to traffic at the time of 2019 data collection (factored up to 2021), an assumption has been made for the percentage transfer of existing traffic to Newhaven Port East Quay which currently routes along Railway Road / Clifton Road and would move onto the New Access Road. For completion of a robust assessment, it is assumed that 80% of the currently average daily traffic on the existing Railway Road / Clifton Road route will reassign to the New Port Access Road.
- 3.2.17 **Table 3-6** sets out the AADF for 2019 and the current baseline (2021). 2021 base traffic includes for the transfer of 80% of the traffic from the existing access to Newhaven Port corridor; as described above.

Table 3-6 2021 baseline traffic data (AADF) – Study Area 2

Highways Link	Historic Traffic Data			2021 Base		
	Total Vehicles	HGVs	Year of Data	Total Vehicles	HGVs	HGV%
1	N/A	N/A	N/A	2829	233	8.2%
2	16873	1267	2019	17346	1277	7.4%
3	16873	1267	2019	17346	1277	7.4%
4	36734	1921	2019	37781	1935	5.1%
5	26348	1095	2019	27106	1103	4.1%

Future baseline

Study Area 1 – Onshore works

Traffic growth

Construction impacts

- 3.2.18 To understand the transport effects during the construction phase, the traffic generation calculations were interrogated to identify a single peak week across the study area for all receptors on highways links, i.e. the week during the construction programme when the number of vehicle trips being generated is forecast to be highest.
- 3.2.19 It has been agreed with WSCC and NH that growth rates can be derived from TEMPro and there is no requirement to include committed development or Local Plan allocations as the growth within the TEMPro estimates will account for traffic growth related to future development in the area through Local Plan allocations.
- 3.2.20 Furthermore, the Department for Transport (DfT) has confirmed that the A27 Arundel Bypass scheme will be deferred to Road Investment Strategy (RIS3 covering 2025 to 2030) to allow time for stakeholders' views to be fully considered. Therefore, as the A27 Arundel Bypass is not yet committed, no cumulative effects assessment has been included with the Proposed Development.
- 3.2.21 The growth rates from TEMPro are as follows:
- 2021 – 2025 – Arun - 1.066 / Horsham – 1.069;
 - 2021 – 2026 – Arun – 1.0746 / Horsham – 1.0788;
 - 2021 – 2027 – Arun – 1.0831 / Horsham – 1.0868; and
 - 2021 – 2028 – Arun – 1.092 / Horsham – 1.095.
- 3.2.22 The HGV growth rates derived from the DfT Transport Statistics are as follows:
- 2021 – 2025 – 1.062;
 - 2021 – 2026 – 1.075;
 - 2021 – 2027 – 1.093; and
 - 2021 – 2028 – 1.109.
- 3.2.23 The following growth rates have been applied to the new base survey flows for the new receptors:
- 2023 – 2025 – Horsham 1.022
 - 2023 – 2027 – Horsham 1.041
 - 2024 – 2026 – Horsham 1.021
 - 2024 – 2028 – Horsham 1.030

- 3.2.24 The following HGV growth rates have been applied to the base survey flows for the new receptor:
- 2023 – 2025 – 1.031;
 - 2023 – 2026 – 1.0465; and
 - 2023 – 2027 – 1.062.
 - 2024 – 2026 – 1.020; and
 - 2024 – 2028 – 1.041.
- 3.2.25 The resultant future year traffic generation is set out in **Table 2-6** and **Table 2-7** of **Chapter 32: ES Addendum** of the ES (Document Reference: 6.2.32).

Decommissioning impacts

- 3.2.26 The temporal scope of the assessment of the decommissioning phase is based on the peak period of traffic during the onshore substation removal. It is currently predicted that the onshore substation will be decommissioned around 30 years from the Proposed Development commission. The onshore substation is proposed to be built in years two to four of the construction programme. Based on the assessments set out on this TGTN, year five will be 2030 and 30 years from then will be 2060.
- 3.2.27 It has been agreed with WSCC and NH that growth rates can be derived from TEMPro and there is no requirement to include committed development or Local Plan allocations as the growth within the TEMPro estimates will account for traffic growth related to future development in the area through Local Plan allocations. For the decommissioning phase impacts assessment, TEMPro rates have been extracted for Horsham.
- 3.2.28 TEMPro only provide traffic estimates to 2051 as this is the latest year for which a reliable traffic growth estimate can be made. Therefore, 2051 is used for the assessment for the decommissioning phase in this TGTN.
- 3.2.29 The growth rates from TEMPro are as follows:
- 2021 – 2051 – Horsham – 1.22.
- 3.2.30 The HGV growth rates derived from the DfT Transport Statistics based on the construction phase HGV growth methodology will result in HGV growth of 1.55% per year which over 30 years to 2051 will result an increase in HGVs of 46.50%. Although this almost doubling of HGVs in 30 years may not be reached (in recent years HGV growth has slowed) it has been used for calculations in this TGTN for consistency with other assessments.
- 2021 – 2051 – 1.4650.
- 3.2.31 The resultant future year traffic generation is set out in **Table 2-6** and **Table 2-7** of **Chapter 32: ES Addendum** of the ES (Document Reference: 6.2.32).

Future highways network changes (construction and decommissioning phases)

- 3.2.32 During initial consultation, WSCC confirmed that there are no highways schemes that will need to be considered in the assessment.
- 3.2.33 The A27 Arundel Bypass is being promoted by NH but is not a committed development. With no direct impacts of onshore elements of the Proposed Development across the proposed route of the A27 Arundel Bypass, the only effects of the onshore elements of the Proposed Development on the bypass will be the additional traffic generated during the construction phase. Highways Link 9 (As shown in **Figure 23.20, Volume 3** of the ES (Document Reference: 6.3.23) has been selected to provide NH with an indication of the peak construction traffic on the A27 which will switch to an open A27 Arundel Bypass. The Department for Transport has confirmed that the A27 Arundel Bypass scheme will be deferred to Road Investment Strategy (RIS3 (covering 2025 to 2030) to allow time for stakeholders' views to be fully considered. Therefore, as the A27 Arundel Bypass is not yet committed, it is not included within the cumulative effects assessment in **Chapter 23: Transport, Volume 2** of the ES [APP-064] or this TGTN, since it is not considered that the A27 Arundel Bypass would either be open or past its peak point of construction by the time that construction of the Proposed Development is complete.
- 3.2.34 The Lyminster Bypass construction works commenced on 24 October 2022 and the scheme completion is currently forecast for Autumn 2024. The bypass will link to the existing A284 from a point approximately 600m south of the A27 at Crossbush and join the privately developed section of the same proposed bypass at Toddington Nurseries. The proposed bypass will be a 7.3m wide single dual carriageway with verge on one side and a shared footway/cycleway facility on the other. The footway/cycleway will connect to existing and proposed facilities along the southern half of the bypass and A259. The Lyminster Bypass is due to be completed ahead of the peak of any Rampion 2 construction works. In order to present a robust scenario, the Rampion 2 traffic modelling has assumed that no Rampion 2 construction traffic would use the Lyminster Bypass and would instead use the existing road network; in practice, the presence of the Lyminster Bypass would relieve pressure on the existing road network. The cumulative highways assessment therefore does not include the Lyminster Bypass, so as to provide a robust assessment.
- 3.2.35 West Sussex County Council (WSCC) is currently developing a major road enhancement scheme for the corridor of the A259 between Bognor Regis and Littlehampton in Arun District. The location of the scheme is between and including the B2132 Yapton Road (Comet Corner) junction and the B2187 Bridge Road (Tesco) junction. Construction commencement, subject to Full Business Case approval, is predicted to be the middle of 2025. As the scheme does not yet have a full Business Case it has not been included in the cumulative effects assessment in **Chapter 23: Transport, Volume 2** of the ES [APP-064] or this TGTN, however a sensitivity test could be undertaken if the A259 scheme were to get full business case approval.

Study Area 2 – Onshore impacts of offshore works

Traffic growth

- 3.2.36 Onshore impacts of the offshore operation and maintenance phase are proposed to start in the first year of commission. With the construction phase ending in 2029, a future year of assessment of 2030 for this operation and maintenance phase has been assumed for assessment in this TGTN.
- 3.2.37 It has been agreed with WSCC and NH that growth rates can be derived from TEMPro and there is no requirement to include committed development or Local Plan allocations as the growth within the TEMPro estimates will account for traffic growth related to future development in the area and it is proposed to continue that approach for Study Area 2. The growth rates are based on the Newhaven (TEMPro data set Lewes 008/009) location in TEMPro as that is where the candidate port is located.
- 3.2.38 The growth rates from TEMPro are as follows:
- 2021 – 2030 – 1.0746.
- 3.2.39 The HGV growth rates derived from the DfT Transport Statistics are as follows:
- 2021 – 2030 – 1.1395.
- 3.2.40 The resultant future year traffic generation is set out in **Table 2-6** and **Table 2-7** of **Chapter 32: ES Addendum** of the ES (Document Reference: 6.2.32).

4. Proposed Development

4.1 The onshore elements of the Proposed Development

4.1.1 The onshore elements of the Proposed Development will include the construction of a temporary onshore cable corridor from landfall at Climping to a new onshore substation at Oakendene near Cowfold, that will connect to the existing National Grid Bolney substation, Mid Sussex, via buried onshore cables.

Onshore cable corridor

4.1.2 The onshore cable corridor will cover an approximate distance of 38.8km and will be buried along its entire length. For construction purposes, a nominal working width up to 40m will be required for the majority of the onshore cable corridor, with some larger working areas required at key areas, while constraints may restrict the working width in other areas.

4.1.3 The onshore cable corridor commences at landfall in Climping, then crosses under the A259, rail network and River Arun via trenchless crossing before also crossing by trenchless method under the A27 near Hammerpot. From here, the onshore cable corridor will head northeast across the South Downs to Washington, West Sussex and under the A24 and A283 via a trenchless crossing. The onshore cable corridor continues northeast through a rural area and to the new onshore substation at Oakendene, that will connect to the existing National Grid Bolney substation via buried onshore cables. Additional infrastructure at the existing Bolney Substation is required to connect the Proposed Development to the National Grid electrical network.

4.1.4 The onshore cable corridor has numerous crossings of roads including the A259, A284, A27, A24, A283, Chanctonbury Ring Road, Spithandle Lane, B2135, B2116, A281, King's Lane, Kent Street, and Wineham Lane. There is also one crossing of the River Arun and two crossings of the National Rail network west of Littlehampton and Wick. Installation of the onshore cable will utilise trenchless crossing techniques (e.g. HDD) to avoid major roads at specific locations, operating railway lines and watercourses.

4.1.5 For the purpose of this assessment, the entire onshore cable corridor has been split into three sections which are described below and presented in [Figure 23.2, Volume 3 of Chapter 23: Transport, Volume 2 of the ES \[APP-064\]](#). Each of the sections contains a temporary construction compound (TCC) plus a number of construction accesses, and therefore enables the study area to be studied in greater detail.

- [Section 1](#) runs north from landfall, across the A259, the River Arun and the two railway lines before crossing the A27 near the edge of the South Downs at Hammerpot. This section is rural but runs along the edge of the settlements of Littlehampton, Wick, Lyminster and Crossbush;
- [Section 2](#) runs northeast from the [Section 1](#) boundary to a crossing of the A24 near Washington, West Sussex. Between the A27 and A24, the onshore cable

corridor has minimal interaction with the local highways network and due to the nature of access options, will make use of a continuous temporary construction haul road; and

- **Section 3** runs from the **Section 2** boundary along the A283 corridor before turning northeast to Partridge Green and further east to Bolney. This section is flat and rural in character but with more crossings of roads.

- 4.1.6 The three sections of the onshore cable corridor route associated with each of the three TCC's assessed are presented in **Figure 23.2.1, Annex B**.
- 4.1.7 The onshore cable corridor was divided into three sections to define the number of work fronts required. The key onshore cable construction activities occur over a four-year period. It is assumed that the construction crews will initially work on the southernmost section (Section 1) of the onshore cable corridor, moving on to Section 2 and then Section 3 as set out in **Figure 23.2.1, Annex B**. The sections are in turn broken down into smaller sections defined by access points and crossings.
- 4.1.8 Each of these sections is defined by the presence of a temporary construction compound, plus a number of construction accesses.
- 4.1.9 Temporary construction compounds (TCC's) will be required to store materials and plant as well as form a base for traffic working at the various site locations. The onshore part of the proposed DCO Order Limits allows space for five TCC locations as set out in **Figure 23.3a-c, Volume 3 of Chapter 23: Transport, Volume 2** of the ES **[APP-064]**. The TCCs used in the traffic calculations used in this assessment are as follows:
- TCC 1 –Clipping compound: Site Access A-5, serving Section 1;
 - TCC 2 – Washington compound: Site Access A39, serving Section 2;
 - TCC 3 – Oakendene west compound: Site Access A-62, serving Section 3;
 - Construction compound 4 – Oakendene substation compound: Site Access A-63, serving Section 3; and
 - Construction compound 5 – existing National Grid Bolney substation compound – Site Access A-68, serving Section 3
- 4.1.10 **Figure 23.4a-c, Volume 3** of the ES (Document Reference: 6.3.23) sets out the onshore cable corridor sections and the TCCs.
- 4.1.11 The operational lifetime of the Proposed Development is expected to be around 30 years and for the purposes of this TGTN at year 30 the Proposed Development will reach the decommissioning phase.
- 4.1.12 Taking place after construction and commissioning of the Proposed Development, the operation and maintenance phase activities can be divided into three main categories:
- scheduled maintenance;
 - unscheduled maintenance; and
 - special maintenance in the event of major equipment breakdown and repairs.

Construction phase working hours

- 4.1.13 Core working hours for construction of the onshore components will be 08:00 to 18:00 Monday to Friday, and 08:00 to 13:00 on Saturdays, apart from specific circumstances that are set out in the **Outline Code of Construction Practice (COCP) [PEPD-033]**, where extended and continuous periods of construction are required.
- 4.1.14 Prior to and following the core working hours Monday to Friday, a ‘shoulder hour’ for mobilisation and shut down will be applied (07:00 to 08:00 and 18:00 to 19:00). The activities permitted during the shoulder hours include staff arrivals and departures, briefings and toolbox talks, deliveries to site and unloading, and activities including site and safety inspections and plant maintenance. Such activities shall not include use of heavy plant or activity resulting in impacts, ground breaking or earthworks.
- 4.1.15 The requirement for deliveries during shoulder hours and potential restrictions to avoid sensitive receptors (where specifically justified or required) will be determined during detailed design once the construction programme has been developed further. Such restrictions can be included within detailed construction traffic management strategies, which would need to be approved West Sussex County Council and the relevant Local Planning Authority in accordance with Requirement 24 of the **Draft Development Consent Order [REP4-004]**.
- 4.1.16 No activity outside these hours including Sundays, public holidays or bank holidays will take place apart from under the following circumstances:
- where continuous periods (up to 24 hours, 7 days per week) of construction work are required for HDD²;
 - for other works requiring extended working hours such as concrete pouring which will require the relevant planning authority to be notified at least 72 hours in advance;
 - for the delivery of abnormal loads to the connection works, which may cause congestion on the local road network, and will require the relevant highway authority to be notified at least 72 hours in advance; or
 - as otherwise agreed in writing with the relevant planning authority.
- 4.1.17 For the purposes of a robust assessment in this TGTN, traffic generation has only been calculated for a five day working week and with no Saturday working.
- 4.1.18 It is anticipated that heavy goods vehicles (HGVs) will be required during the enabling and construction phases of the Proposed Development.

Operation and maintenance phase

- 4.1.19 Following the construction phase, the operation and maintenance phase activities can be divided into three main categories:

² HDD is a continuous activity and cannot be paused once started.

- scheduled maintenance;
- unscheduled maintenance; and
- special maintenance in the event of major equipment breakdown and repairs.

- 4.1.20 A key principle is that the wind farm will be designed to operate under minimum supervisory input. Maintenance of the onshore cable is expected to be minimal. During the operation and maintenance phase, periodic testing of the cable is likely to be required (every two to five years). This will require access to the link boxes at defined inspection points along the onshore cable corridor. This will involve attendance by up to three light vehicles, such as vans, in a day at any one location. The vehicles will gain access using existing field accesses and side accesses as agreed with landowners to reach the relevant sections of the onshore cable.
- 4.1.21 For the onshore cable, unscheduled maintenance or emergency repair visits will typically involve a very small number of vehicles, typically light vans. Infrequently, equipment may be required to be replaced, then the use of an occasional HGV may be utilised, depending on the nature of the repair.
- 4.1.22 Vehicle movements during operation and maintenance phase of the onshore substation will be small, comprising occasional inspection and maintenance requirements. Its considered this traffic will be negligible and there not been assessed.
- 4.1.23 The operational lifetime of the Proposed Development is expected to be around 30 years and for the purposes of this TGTN at year 30 the Proposed Development will reach the decommissioning phase.

Decommissioning phase

- 4.1.24 A decommissioning plan and programme will be developed prior to construction and updated during operation of the Proposed Development to account for any changes to decommissioning best-practice and developments in technology.
- 4.1.25 The decommissioning phase is anticipated to involve the removal of offshore infrastructure above the seabed, and the removal and reinstatement of the onshore substation site. The cable will be left in place to avoid disturbance. The decommissioning works are likely to be undertaken in reverse to the sequence of construction works and involve similar levels of equipment but much reduced numbers of vehicles for decommissioning.

4.2 The offshore elements of the Proposed Development

- 4.2.1 The key offshore elements of the Proposed Development will be as follows:
- up to 90 offshore wind turbine generators (WTGs) and associated foundations;
 - blade tip of the WTGs will be up to 325m above Lowest Astronomical Tide (LAT) and will have a 22m minimum air gap above Mean High Water Springs (MHWS);
 - inter-array cables connecting the WTGs to up to three offshore substations;

- up to two offshore interconnector export cables between the offshore substations;
- up to four offshore export cables each in its own trench, will be buried under the seabed within the final cable corridor; and
- the export cable circuits will be High Voltage Alternating Current (HVAC), with a voltage of up to 275kV.

Construction phase

- 4.2.2 During the construction phase, it is anticipated that 2,000+ two way movements for crew support vessels from the onshore ports to the offshore infrastructure, however it is not established how this will be organised.
- 4.2.3 The construction of the Rampion 1 project resulted in staff arriving and departing numerous ports in the UK and Europe and it is likely this process will be undertaken for Rampion 2.
- 4.2.4 A maximum of 6 crew transfer vessels (which can typically carry 12 to 16 passengers and equipment) is required with 180 return trips³ (360 two-way movements) for all three offshore substations during the offshore substation vessel installation.
- 4.2.5 A maximum of 10 crew transfer vessels (which can typically carry 12 to 16 passengers and equipment) would be required with 1800 two-way movements for the smaller wind turbine generator type during the offshore installation.
- 4.2.6 Alternatively, a maximum of 6 crew transfer vessels (which can typically carry 12 to 16 passengers and equipment) would be required with 600 two-way movements for the larger wind turbine generator type during the offshore installation.
- 4.2.7 Material, including large transformers, cable and WTG components are expected to be delivered directly from European manufacturing bases. WTG construction vessels are also usually moored in European ports or will transfer from other projects.
- 4.2.8 There will also be some onshore works required in the offshore works but these construction activities (construction compound setup, HDD, Transition Joint Bay (TJB) construction etc.) have relatively short durations compared with the overall landfall construction presented in this TGTN for the construction phase of the landfall site (onshore). Due to the landfall works requiring offshore works, the scheduling of the landfall works will allow for flexibility around the offshore schedule and sufficient time for all onshore activities to be performed so as not to delay the offshore works.
- 4.2.9 Consequently, the onshore impacts of the offshore process (i.e. transferring construction workers to ports to connect to offshore transfers) would have a limited impact onshore compared to the movement of freight. Offshore construction worker movements have been considered as part of the onshore assessment.

³ One return trip comprises 2 two-way movements in total

Operation and maintenance phase

- 4.2.10 The operational lifetime of the Proposed Development is expected to be around 30 years and for the purposes of this TGTN at year 30 the Proposed Development will reach the decommissioning phase. It is only anticipated that elements of the Proposed Development that are above sea level will be removed (WTG / substations).
- 4.2.11 When the offshore elements of the Proposed Development are constructed and commissioned staff will be required to continue to operate and maintain the WTGs and associated infrastructure. RED will draw on experience gained in operating and maintaining the existing Rampion 1 project and although the maintenance port and facilities are not yet confirmed, for the purpose of this TGTN it is assumed that the existing operation and maintenance base Newhaven East Quay will be used for staffing.

5. Key Construction Traffic Assumptions

5.1 Introduction

5.1.1 This Section provides a summary of key assumptions that have been used to calculate construction traffic generation across all elements of the of Proposed Development.

5.2 Overview

5.2.1 The construction works have been based on the following onshore cable connection design. A maximum of 20 buried cables will run along the length of the onshore cable route from the landfall at Climping through to the new onshore substation at Oakendene. A maximum of 10 buried cables will subsequently run from the new onshore substation to connect into the existing National Grid Bolney substation.

5.2.2 The up to 275kV cable system along the onshore cable route will comprise four cable circuits in separate trenches. Each circuit will contain three Power Cables (HVACs) and two Fibre Optic Cables (FOCs) drawn through pre-installed ducts.

5.2.3 The 400kV cable system between the new onshore substation at Oakendene and the existing National Grid Bolney substation will comprise two cable circuits in separate trenches. Each circuit will contain three Power Cables and two FOCs drawn through pre-installed ducts. In order to undertake calculations of vehicle movements associated with the construction phase of the onshore elements of the Proposed Development, a fixed scheme is required with regards to onshore cable corridor, onshore substation location and TCC locations. To inform these calculations, vehicle movements have been calculated for each construction site and key assumptions associated with these are discussed in the following subsections for:

- onshore cable corridor;
- TCCs;
- onshore substation; and
- temporary construction accesses.

5.3 Onshore cable corridor

5.3.1 The onshore cable corridor is routed from the landfall at Climping through to a proposed new onshore substation at Oakendene, and then onto the existing National Grid Bolney substation.

5.3.2 Temporary access points along the onshore cable route have been identified. These accesses may be utilised in different ways, due to safety and efficiency, for example traffic may enter and exit via different accesses whilst making deliveries

to site. For the purposes of this assessment, access to and from the onshore cable route is assumed through the access points as set out in **Table 5-1**.

Table 5-1 Accesses

Access	Access Type
A-01	Construction and operational
A-02	Light construction
A-03	Light construction
A-04	Operational
A-05	Construction and operational
A-06	Operational
A-08	Light construction
A-09	Construction and operational
A-10	Operational
A-11	Operational
A-12	Construction
A-13	Construction and operation
A-14	Light construction and operational
A-15	Construction and operational
A-16	Construction and operational
A-17	Operational
A-18	Operational
A-20	Light Construction and operational
A-21	Construction
A-22	Construction
A-23	Operational
A-24	Operational
A-25	Light construction and operational
A-26	Construction and operational

Access	Access Type
A-27	Operational
A-28	Construction
A-29	Operational
A-30	Operational
A-31	Operational
A-32	Operational
A-33	Construction
A-34	Operational
A-35	Construction
A-36	Operational
A-37	Light construction
A-38	Light construction
A-39	Construction and operational
A-40	Construction and operational
A-41	Construction and operational
A-42	Construction and operational
A-43	Construction and operational
A-43-a	Construction
A-43b	Operational
A-44	Operational
A-45	Operational
A-46	Light construction and operational
A-47	Construction and operational
A-48	Construction and operational
A-49	Light construction and operational
A-50	Construction and operational

Access	Access Type
A-50a	Construction
A-50b	Operational
A-51	Operational
A-52	Construction and operational
A-53	Construction
A-54	Operational
A-55	Operational
A-56	Construction and operational
A-57	Construction and operational
A-58	Operational
A-59	Operational
A-60	Operational
A-61	Construction and operational
A-62	Construction
A-63	Construction and operational
A-64	Construction and operational
A-65	Operational
A-66	Light construction and operational
A-67	Construction and operational
A-68	Construction
A-69	Operational

5.3.3 The temporary construction access points are required along the onshore cable corridor to allow the transportation of materials, equipment, and personnel to and from the construction sites. These temporary construction access points will allow access to the construction corridor where there will be a temporary construction haul road running along the length of the onshore cable route, except for locations where there are trenchless or road crossings. These accesses may be utilised in different ways, due to safety and efficiency, for example traffic may enter and exit via different accesses whilst making deliveries.

- 5.3.4 Potential temporary construction access points along the onshore cable corridor were identified based on suitability for the Proposed Development requirements. Existing access points and tracks have been utilised where possible. These temporary construction and operational accesses may be utilised in different ways due to safety and efficiency, for example construction traffic may use one access for incoming traffic to an onshore cable corridor section and another access for traffic to exit. For the purposes of this assessment, access to and from the onshore cable corridor is assumed through the same access point.
- 5.3.5 The **Outline Construction Traffic Management Plan (CTMP) [REP5-068]** includes more detail on the temporary construction access points.

5.4 Temporary construction compounds

- 5.4.1 A number of TCCs will be required to support the construction of the onshore elements of the Proposed Development and will be used to store materials and form a base for traffic travelling to and from construction site locations. These TCCs are outlined in **Section 4.1**.

5.5 Onshore substation

- 5.5.1 The purpose of the new onshore substation at Oakendene is to increase the onshore cable route voltage from the export voltage to the 400kV required to connect to the existing National Grid Bolney substation.
- 5.5.2 Access to the onshore substation will be required during construction as well as operation and maintenance. The temporary construction access route will be used for the duration of the onshore substation construction works.
- 5.5.3 Temporary construction activities for the onshore substation will include enabling works and construction works. Enabling works will prepare the site ahead of construction and include vegetation clearance, access road construction, installation of drainage systems, stone fill, installation of a temporary construction compound, delivery of materials, plant, machinery and fuel, and any earthworks necessary for the installation of the substation foundations.
- 5.5.4 Generally, onshore substation construction will take place during daylight hours with a requirement only for local task lighting. Construction works will involve:
- landscaping;
 - installation of perimeter fencing;
 - ground preparation works;
 - installation of underground services and onshore substation foundations;
 - construction of the control and switchgear buildings and plant buildings;
 - construction of cable trenches;
 - construction of ducts and pits;
 - construction of the oil containment bund; and

- provision of utility supplies.

- 5.5.5 Once all construction activities have been carried out, the electrical equipment will be installed, commissioned and tested for the performance of the connection between Oakendene and the existing National Grid Bolney substation. Finally, the site will be secured, and the temporary area returned to its original use and condition.
- 5.5.6 It is anticipated that heavy goods vehicles (HGVs) will be required during the enabling and construction phases of the development.

Abnormal Indivisible Loads (AILs)

- 5.5.7 It is anticipated that Abnormal indivisible load (AIL) movements are expected to be required during the construction phase to transport permanent plant and equipment to the site. The expected AIL movements are described in **Appendix 23.1: Abnormal Indivisible Loads assessment, Volume 4** of the of the ES [APP-196].
- 5.5.8 There will be up to 10 two-way movements delivering abnormal indivisible loads to the Oakendene substation.
- 5.5.9 AILs will be comprised of:
- Up to four main transformers; and
 - Six shunt reactors.
- 5.5.10 This figure reflects the update contained within the errata items included in Appendix 3 of the Applicant's cover level to the Pre-Examination Procedural Deadline (PEPD-001).

5.6 Work section breakdown

- 5.6.1 The three sections of the onshore cable corridor route associated with each of the three TCC's assessed is presented in **Figure 23.2.1, Annex B**.
- 5.6.2 The onshore cable corridor has been divided into sections to define the number of work fronts required. The key onshore cable construction activities occur over a four-year period. It is assumed that the construction crews will initially work on the southernmost section (Section 1) of the onshore cable corridor, moving on to Section 2 and then Section 3 as set out in **Figure 23.2.1, Annex B**. The sections are in turn broken down into smaller sections defined by access points and crossings.
- 5.6.3 Each of these sections is defined by the presence of a Temporary Construction Compound (TCC), plus a number of construction accesses.

5.7 Construction activities

- 5.7.1 During the construction phase, construction activities have been divided into the following activities:
- horizontal directional drill (HDD) construction compound works;

- HDD drilling;
- TCC mobilisation;
- temporary compound construction;
- haul roads;
- landfall works;
- clearing works;
- temporary construction access works
- materials deliveries;
- trenching;
- all joint bay works;
- duct installation, cable pulling and reinstatement;
- temporary construction access road / haul road reinstatement;
- compound reinstatement; and
- onshore substation construction.

5.7.2 The construction traffic generation of all elements of the works has been predicted across the proposed construction schedule (2025-2029). This has resulted in vehicle movement predictions on a weekly basis per access point for each work site, split into Heavy Goods Vehicles (HGVs) and Light Goods Vehicles (LGVs).

5.8 Construction Management Base

5.8.1 During the construction phase, the onshore elements of the Proposed Development would be supported with Temporary Construction Compounds (TCC's) (and HDD compounds), accesses and haul roads. There will also be some traffic during the construction phase associated with the construction management base in Shoreham, from where crew transfer onto vessels.

5.8.2 A management team, marine co-ordination and vessel management team will be based in the office, and some contractors may use the office facility as well. These teams will comprise around 24 people in total and will be assumed to be shore-based for robustness.

5.8.3 The construction management base will enable Crew Transfer Vessels (CTV) to access the offshore construction location. The construction management base will also enable CTV crew transfers to complete construction and commissioning work.

5.8.4 The base will feature facilities including:

- Temporary modular offices, with welfare and changing facilities;
- Car parking; and
- Temporary pontoons with a fuelling facility.

5.8.5 It has been assumed that 40 workers per day will travel to the Construction Management Base (CMB) for onward transfer by CTV, and they have the same spatial distribution as workers based at TCC 1. The remainder of the LV traffic is assumed to be LGVs and similarly follows the spatial distribution for TCC 1 deliveries. There are also some HGVs serving the base, and it is assumed that the HGV distribution is followed with respect to these.

5.9 Scheduling

5.9.1 An indicative construction programme for the Proposed Development is presented in **Graphic 5-1**. The programme illustrates the anticipated duration of the major construction / installation elements. The anticipated worst-case total construction duration for all onshore infrastructure to be complete, operational and for full landscape reinstatement is approximately four years.

5.9.2 Each construction activity has been scheduled to overlap activities where necessary across the construction schedule. This has involved both paralleling some construction activities where practical and increasing the overall duration for other construction activities, as shown in **Graphic 5-1**.

Graphic 5-1 Overall Construction Schedule

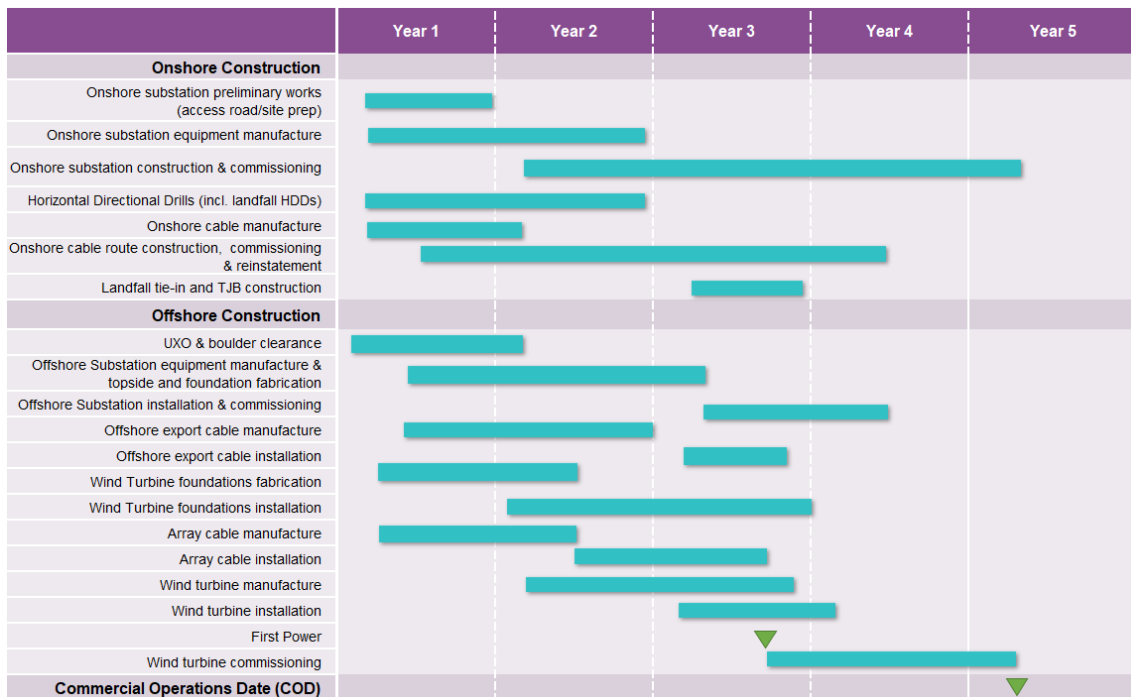

5.10 Construction materials, personnel, plant and equipment requirements

5.10.1 Construction personnel and plant / equipment requirements have been assessed at a high level for the purposes of estimating the number of HGVs required, as well as LGVs required to bring workers to onshore part of the proposed DCO Order Limits. Typically, this is via multi-occupancy vehicles to TCCs, before travelling to

specific construction accesses that are part of the onshore part of the proposed DCO Order Limits via five person welfare vans.

- 5.10.2 As the volume of required construction plant/equipment is anticipated to be relatively low in comparison to other construction activities (e.g. aggregate transportation) associated with the construction of the onshore cable corridor, a high-level estimate has been made only where significant construction plant / equipment requirements are expected.

6. Construction traffic generation

6.1 Assessment methodology

- 6.1.1 This section presents a high-level overview of the method that has been adopted to estimate the vehicle movements of both heavy goods vehicles (HGVs) and light vehicles (LGVs) throughout the construction phase of the onshore elements of the Proposed Development.
- 6.1.2 This section presents a high-level overview of the method that has been adopted to estimate the vehicle movements of both heavy goods vehicles (HGVs) and light vehicles (LGVs) throughout the construction phase of the onshore elements of the Proposed Development.
- 6.1.3 In this TGTN, a vehicle movement has been defined as a one-way journey between two locations. For example, an HGV delivering cables to a TCC and then leaving empty is considered two journeys. A subsequent further two journeys are then required to deliver the cables from the TCC to site (one loaded, one empty).
- 6.1.4 The estimates within this TGTN have been calculated against a conservative set of assumptions based on the best available information on the onshore works within the proposed DCO Order Limits. The final arrangement of the construction works, and precise methods used will be determined during the detailed design stage and the construction phase of the works depending on the working arrangements favoured by the appointed contractor(s). These factors will influence the number of vehicle movements and the personnel requirements.
- 6.1.5 For this assessment, each of the construction work sites has been treated separately. Each construction work site along the onshore temporary construction corridor has been broken down into the different activities required. Each activity has then been assessed individually for its requirements.
- 6.1.6 The following key design assumptions have been determined for each activity:
- duration of activity;
 - material and plant required at each work site;
 - length of haul road required;
 - approximate size of construction workforce; and
 - quantity of construction personnel and construction LGVs.
- 6.1.7 Construction traffic vehicle movements associated with the materials required at the onshore cable corridor and onshore substation have been determined based on the latest bill of quantities.

6.2 Total Construction Traffic Movements

- 6.2.1 The approach considers a single onshore cable corridor from landfall through to a single onshore substation before connecting by a single onshore cable corridor into the existing substation.
- 6.2.2 **Table 6-1** presents all vehicle movements pertaining to onshore cable corridor and onshore substation construction, broken down by vehicle type and year. Note that movements are all presented as two-way totals, for example an HGV travelling from base to compound is counted as one movement, and then the HGV returning to its base is counted as one movement, (i.e. a total of two movements).
- 6.2.3 These total construction traffic estimates have been used as a basis for all peak assessment scenarios discussed within this TGTN.

Table 6-1 Two-way vehicle movement summary

Output	Year 1	Year 2	Year 3	Year 4	Total
Peak weekly traffic across the onshore part of the proposed DCO Order Limits – LGV	426	3,510	2,040	1,200	N/A
Peak weekly traffic across the onshore part of the proposed DCO Order Limits – HGV	338	1,146	1,022	1,498	N/A
Total Vehicle Movements – HGVs	4,318	33,790	22,664	8,732	69,504
Total Vehicle Movements – LGVs*	5,790	104,928	6,226	12,180	185,124

6.3 Construction Traffic Distribution

- 6.3.1 The traffic movements were distributed and assigned to a simplified road network diagram for each type of vehicle type, showing two-way movements in and out of the Study Area.

HGVs

- 6.3.2 HGV construction traffic consists of the delivery of materials or equipment directly to the work sites via the access points. The access strategy uses strategic roads as seen in **Table 6-2** for the longest part of the journey as detailed within the [Outline Construction Traffic Management Plan \(CTMP\) \[APP-228\]](#).

Table 6-2 HGV construction traffic distribution

Route	Percentage
A27 West	27.59%
A27 East	20.69%
A23 North	27.59%
A23 South	24.14%
	100%

6.3.3 The HGV Access Strategy has considered all local constraints, together with policies such as those set out in the West Sussex Transport Plan 2022-2036 (WSCC, 2022), to identify local HGV access routes for assessment purposes which are set out in **Table 6-3**.

6.3.4 HGVs would seek to adhere to these routes wherever possible, with certain exceptions, for example, when materials are required to be delivered from a location along a different route (i.e. where it is not possible to follow the assigned routing). Additionally, there may need to be temporary deviations from the HGV routes in the event of an incident on the original route, leading police to redirect HGVs via an alternative route until the incident has been cleared.

Table 6-3 HGV access routes

Route	HGV access route	Accesses served
1	A27, A259, A284, Ferry Road	A-1
2	A27, A259, A284, Church Road	A-5
3	A27, A259, A284,	A-9
4	A27, A259, A284,	A-12, A-13, A-15, A-16
5	A27	A-21, A-22
6	A27, A280	A-26, A-28
7	A27, A280, A24, A283	A-33, A-35, A-39, A-40, A-41, A-42, A-43
8	A27, A283	A-43
9	A27, A280, A24, A283, B2135, Spithandle Lane	A-47

Route	HGV access route	Accesses served
10	A27, A280, A24, A283, B2135	A-48, A-50
11	A27, A280, A24, A283, A2037, A281	A-52
12	A27, A280, A24, A283, A2037, A281, B2116	A-53
13	A23, A272, A281, A27, A283, A2037	A-56, A-57
14	A27, A23, A24, A272	A-62, A-63
15	A27, A23, A24, A272, Kent Street	A-61, A-64
16	A27, A23, A24, A272, Wineham Lane	A-67, A-68

LGVs

- 6.3.5 The local access routes from compound to access (indicated in [Figure 7.6.9a-c](#) of the [Outline CTMP](#) (Document Reference:7.6) and [Table 6-4](#)) have been used to determine the impact of LGV and HGV traffic on Receptors.
- 6.3.6 This LGV routing allowed estimates to be generated of construction traffic flows for all links within the study area, which has then been used to assess the impact of the Proposed Development at identified sensitive receptors.

Table 6-4 LGV access routes

Local access route number	Route via local road network	Temporary construction and operational accesses served
Route 1	A27 - A284 - A259 - Ferry Road or Church Lane	A-01, A-05, A-09, A-13, A-15, A-16, A-20, A21.
Route 2	A27 - A280 - A24 - A283- B2135 – B2116	A-26, A-27, A-28, A-39, A-40, A-41, A-42, A-43, A-47, A-48, A-50, A-53, A-54.
Route 3	A23 - A272 - Wineham Lane or A272 - Kent Street (north of Access A-61 only) or A272 - A281	A-51, A-52, A-56, A-57, A-61, A-63, A-64, A-67, A-68, A-69.

- 6.3.7 The LGV Access Strategy is based on a prediction of the construction traffic generation of all onshore elements of the Proposed Development. The construction traffic generation has been applied to the four-year construction schedule, which has resulted in construction vehicle movement predictions per vehicle type on a weekly basis per access point.
- 6.3.8 LGV construction traffic has been distributed onto the network using the following two methods:
- **LGV traffic (staff and other deliveries)** – This comprises staff driving from home to work at the Temporary Construction Compounds (TCC's), as well as occasional deliveries by LGV to the TCC's. In both cases the spatial distribution has been calculated using the 2011 journey to work census data for three local areas associated with the three sections of the onshore cable corridor of the Proposed Development as seen in **Table 6-5**.
 - **LGV traffic by Multi-Occupancy Vehicle (MOV) (5 staff)** – LGV construction traffic then uses a circular route to drop off staff/materials between the TCC's and the proposed works sites via the access points along the onshore cable corridor. Given there are three compounds there are three circular routes as seen in **Table 6-6**.
- 6.3.9 On this basis, LGVs (staff and deliveries) can use any routes to travel from their home to/from the compounds, there are no prescribed routes. However, three circular routes have been devised to transport staff/deliveries between the compounds and work sites in shared multi-occupancy vehicles.

Table 6-5 LGV construction staff traffic distribution

Entry / Exit points from highways network scope	Construction staff traffic distribution by TCC / onshore substation		
	Section 1	Section 2	Section 3
A259 East	21%	3%	2%
A284 South	33%	2%	1%
A259 West	16%	3%	0%
A23 North	1%	2%	17%
A23 South	3%	3%	6%
A24 North	3%	15%	21%
A3021 south	4%	17%	9%
A27 East	1%	2%	3%
A27 West	9%	2%	0%
A284 North	4%	1%	0%

Entry / Exit points from highways network scope	Construction staff traffic distribution by TCC / onshore substation		
	Section 1	Section 2	Section 3
A283 East	0%	12%	8%
A283 North	0%	0%	0%
A283 West	0%	29%	13%
A272 East	1%	1%	9%
A272 West	0%	2%	3%
A270	3%	6%	6%
A273	0%	0%	0%
A2300	0%	0%	3%
Total	100%	100%	100%

Table 6-6 MOV circular construction routes

Temporary Construction Compound	LGV Multi-Occupancy Vehicle (MOV) circular access routes
Climping compound, off Church Lane	Church Lane (SB), Ferry Road, A259 (NB), A284 (NB), A27 (EB), A280 (NB), A24 (SB), A27 (WB), A284 (SB), A259 (SB), Church Lane (NB)
Washington compound, north of Washington, West Sussex (accessed from A283)	A283 (WB), A283 (EB), B2135 (NB), Spithandle Lane, B2135 (NB), B2116 (WB), A24 (SB), A283 (EB)
Oakendene west compound (accessed from A272)	Bolney Substation, Wineham Lane (NB), A272 (WB), Kent Street (SB) to A-61, Kent Street (NB), A272 (WB), A281 (SB), Wineham Lane (NB).

6.4 Construction traffic generation

- 6.4.1 This section details estimated number of construction vehicle movements, both Heavy Goods Vehicles (HGVs) and Light Goods Vehicles (LGVs) across the study area using the methodology defined in **Section 6.3**.

6.4.2 Construction traffic movements to and from each access have been provided by the project engineering team. These have then been combined with a series of assumptions around routes, occupancy and other relevant factors.

6.4.3 For the purposes of this assessment, access to and from the onshore cable route is assumed through the access points as set out in **Table 6-7**.

Table 6-7 Total two-way construction movements by access

Access ID	Use	Total Two-Way Movements		Comments in relation to ES Addendum
		LGVs	HGVs	
A-01	Construction and operational	2178	1812	N/A
A-02	Light construction	<10	0	10 LGVs included in peak week assessment
A-03	Light construction	<10	0	10 LGVs included in peak week assessment
A-05	Construction and operational	33900	9342	N/A
A-08	Light construction	<10	0	10 LGVs included in peak week assessment
A-09	Construction and operational	1026	1338	N/A
A-12	Construction	456	878	N/A
A-13	Construction and operation	Up to 480	Up to 562	Shared access with A-15
A-14	Light construction and operational	<10	0	10 LGVs included in peak week assessment
A-15	Construction and operational	Up to 480	Up to 562	Shared access with A-13
A-16	Construction and operational	2358	3520	N/A
A-20	Light Construction	<10	0	10 LGVs included in peak week assessment
A-21	Construction	Up to 1500	Up to 2604	Access shared between A-21 and A-22
A-22	Construction			

Access ID	Use	Total Two-Way Movements		Comments in relation to ES Addendum
		LGVs	HGVs	
A-24	Light construction and operational	<10	0	10 LGVs included in peak week assessment
A-25	Light construction and operational	<10	0	10 LGVs included in peak week assessment
A-26	Construction and operational	2238	4892	Access shared between A-26 and A-28
A-28	Construction			
A-33	Construction	1416	2646	N/A
A-35	Construction	60	160	N/A
A-37	Light construction	<10	0	10 LGVs included in peak week assessment
A-38	Light construction	<10	0	10 LGVs included in peak week assessment
A-39	Construction and operational	54546	7660	N/A
A-40	Construction and operational	966	1468	Access shared between A-40 and A-41
A-41	Construction and operational			
A-42	Construction and operational	192	318	N/A
A-43	Construction and operational	1728	3134	N/A
A-46	Light construction and operational	<10	0	10 LGVs included in peak week assessment
A-47	Construction and operational	648	900	N/A
A-48	Construction and operational	672	1416	N/A

Access ID	Use	Total Two-Way Movements		Comments in relation to ES Addendum
		LGVs	HGVs	
A-49	Light construction and operational	<10	0	10 LGVs included in peak week assessment
A-50	Construction and operational	708	1248	N/A
A-52	Construction and operational	<10	1550	N/A
A-53	Construction	<10	0	10 LGVs included in peak week assessment
A-56	Construction and operational	780	1182	N/A
A-57	Construction and operational	1116	1816	N/A
A-61	Construction and operational	828	1320	N/A
A-62	Construction	16338	5778	N/A
A-63	Construction and operational	52254	11438	N/A
A-64	Construction and operational	468	892	N/A
A-66	Light construction and operational	<10	0	10 LGVs included in peak week assessment
A-67	Construction and operational	444	644	N/A
A-68	Construction	7182	986	N/A

Assumptions

6.4.4 The following assumptions have been made to provide a high-level estimate of construction traffic:

- for robustness, weekday traffic numbers have been calculated on the basis of dividing the weekly traffic by five working days per week;

- number of person-days – all workers are assumed to travel to the onshore part of the proposed DCO Order Limits once per day via personal LVs (i.e. cars) with one worker per vehicle (i.e. no car sharing). This is a robust assumption for the purposes of the traffic assessment as, in practice, once the workforce becomes established, some degree of car sharing may take place;
- plant and equipment required to complete each construction activity will be stored on the various construction sites (along the onshore cable corridor) that form part of the onshore part of the proposed DCO Order Limits, as opposed to within TCC's. As a result, plant and equipment is associated with only two movements (access and egress) per temporary construction access point;
- all materials are brought directly to the construction sites that are part of the onshore part of the proposed DCO Order Limits, with exception of cement bound sand (CBS), cables and ducts, which will first be stored within TCCs; and
- LGV quantities assume up to five individuals per shared vehicle, and one individual per car arriving at TCCs;
- 2011 Census Journey to Work Data was used to estimate home (or temporary home) locations of the construction workforce, which was then sense checked. The results reflect a workforce which will both aim to encourage local employment as well as uptake of local accommodation by some workers sourced from further afield; and
- For robustness, for the purpose of the traffic analysis, all workers were assumed to travel by car and without car sharing taking place; in practice, there will be measures to encourage sustainable travel amongst the workforce, as set out in the [Outline CWTP \[APP-229\]](#) and [Outline OTP \[APP-227\]](#).
- All light construction accesses generate 10 LGV movements during the peak construction traffic week.
- Where optionality exists between use of accesses (e.g. A13/A15) all construction traffic uses whichever access results in a worst-case impact on nearby receptors.

6.5 ES Chapter 23 Peak Construction Scenarios

6.5.1 Using the construction traffic generation assumptions contained within this TGTN the impact of the Proposed Development at its peak has been assessed in [Chapter 32: ES Addendum, Volume 2](#) of the Environmental Statement (ES) [\[REP1-006\]](#) by comparing estimates of construction traffic generated by the Proposed Development with future predicted baseline traffic flows on the road links. This has been completed for different construction traffic scenarios to account for different construction activity peaks across the programme and along the onshore cable corridor as summarised in below:

- **Peak Week 70:** Construction traffic associated with the peak week of four-year construction programme (as summarised in Table 23-36 of [Chapter 32: ES Addendum, Volume 2](#) of the ES [\[REP1-006\]](#)):
 - ▶ The peak week has been obtained by calculating the total number of vehicle trips for all accesses in each week (regardless of whether the trips are LGV

or HGV). The peak week has been used to assess each individual receptor which may be impacted by construction traffic associated with that access, thereby offering both a consistent approach (since all traffic flows are from the same week) as well as a robust approach (since it is the peak week as calculated across the entire study area). This same method has been used to identify the peak weeks for each of the three sections outlined below.

- **Section-based peak weeks:** As part of the Proposed Development the entire onshore temporary cable corridor was split into three sections:
 - ▶ **Section 1** runs north from landfall, across the A259, the River Arun and the two railway lines before crossing the A27 near the edge of the South Downs at Warningcamp. This section is rural but runs along the edge of the settlements of Littlehampton, Wick, Lyminster and Crossbush. The peak week for section 1 has been identified as week 72 of the construction programme;
 - ▶ **Section 2** runs north east from the Section 1 boundary to a crossing of the A24 near Washington, West Sussex. Between the A27 and A24, the onshore cable corridor has minimal interaction with the local highways network and due to the nature of access options, will make use of a continuous haul road. The peak week for section 2 has been identified as week 83 of the construction programme; and
 - ▶ **Section 3** runs from the Section 2 boundary along the A283 corridor before turning north east to Partridge Green and further East to Wineham/Bolney. This section is flat and rural in character but with more crossings of roads. The peak week for section 3 has been identified as week 125 of the construction programme
- **Annual Average Weekday Traffic (AAWT)** for year 1, 2, 3 and 4 of the construction programmes (as summarised in Table 23-38 of **Chapter 32: ES Addendum, Volume 2** of the Environmental Statement (ES) [REP1-006].

6.6 ES Addendum Further Sensitivity Tests

- 6.6.1 A further sensitivity test has been undertaken which assesses the peak week for construction traffic at each receptor. The week used to assess the impact has been based on the peak week in total construction traffic and the peak week of HGV construction traffic. Whilst recognising that this is an unrealistic scenario in practice due to those weeks occurring at different weeks in the programme, it enables the worst case for each receptor to be considered. A summary of the methodology used as part of this additional sensitivity test and the outcomes of the assessment are outlined below.

Total Construction Traffic Peak

- 6.6.2 This assignment exercise was used to calculate peak construction traffic flows (two-way movements) by access, for each type of construction vehicle (LGVs, LGV MOVs and HGVs) for each week of the construction programme. This produced 612 separate road network diagrams (204 for LGV, 204 for LGV MOV and 204 for HGV) one for each week of the construction programme **Graphic 6-1**

shows an excerpt from the Week 2 road network diagram, which shows 12 one-way movements, or 24 two-way movements pass Receptor 2 on Church Lane

Graphic 6-1 Week 2, Total Peak Week excerpt from network diagram

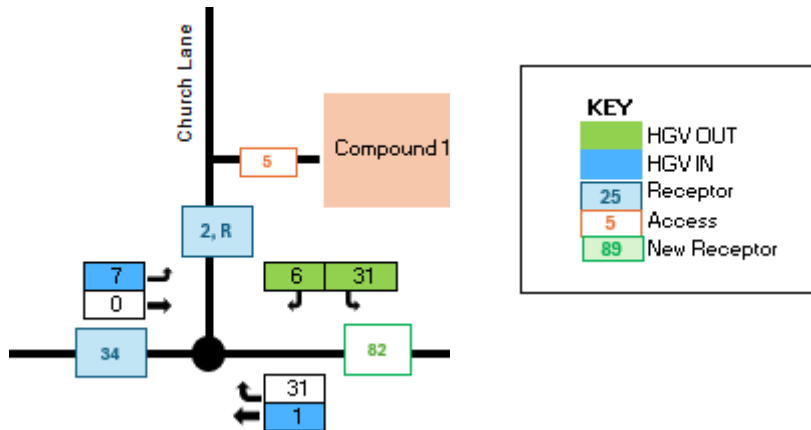

6.6.3 From these network diagrams, three separate matrices showing two-way movements (using the turning movements either side of each receptor) have been developed for LGVs, LGV MOVs and HGVs by week and receptor. These three matrices have then been summed to provide a matrix for the Total vehicles (HGV+ LGV+LGV MOV) for each week as seen in the example in **Graphic 6-2** and the cumulative impact on each receptor.

Graphic 6-2 Total vehicles on a week-by-week basis

	A	B	C	D	E	F	G	H	I	J	K	L	M	N	O
1 Week	Receptor		1	2	3	4	5	6	7	8	9	10	11	12	13
2	0		16	75.56674	20.89213	8.130132	63.44298	20.37444	20.37444	0	10.79031	0	18.07149	5.969181	5.969181
3	1		16	75.56674	20.89213	8.130132	63.44298	20.37444	20.37444	0	10.79031	0	18.07149	5.969181	5.969181
4	2		16	75.56674	20.89213	8.130132	63.44298	20.37444	20.37444	0	10.79031	0	18.07149	5.969181	5.969181
5	3		16	75.56674	20.89213	8.130132	63.44298	20.37444	20.37444	0	10.79031	0	18.07149	5.969181	5.969181
6	4		16	75.56674	20.89213	8.130132	63.44298	20.37444	20.37444	0	10.79031	0	18.07149	5.969181	5.969181
7	5		16	75.56674	20.89213	8.130132	63.44298	20.37444	20.37444	0	10.79031	0	18.07149	5.969181	5.969181

6.6.4 This total has then been used to determine the peak week for each receptor as seen in **Graphic 6-3**. For example, Receptor 6 the peak Week is 72. Therefore, the peak impact at Receptor 6 in Week 72, is 227 HGVs and 462 LGVs (128 LGVs + 334 LGV MOVs).

Graphic 6-3 Impact Assessment based on Total peak week

Receptor	Total				Week Start	Week End	HGV Value	LGV Value	MOV Value	LGV+MOV Value
	Value	Week Start	Week End	Week Start						
1	469	70	70	70	70	160	0	309	309	
2	1837	72	72	72	72	256	1247	334	1581	
3	436	72	72	72	72	0	436	0	436	
4	441	162	162	162	162	403	38	0	38	
5	1559	72	72	72	72	227	998	334	1332	
6	690	72	72	72	72	227	128	334	462	
7	690	72	72	72	72	227	128	334	462	

HGVS Construction Traffic Peak

6.6.5 Similarly, a sensitivity test has also been undertaken using the HGVS peak week as seen in **Graphic 6-4**. For example, Receptor 6 the peak Week is 83. Therefore, the peak impact at Receptor 6 in Week 83, is 248 HGVS and 281 LGVS (59 LGVS + 222 LGV MOVs).

Graphic 6-4 Impact Assessment based on HGVS peak week

Receptor	HGVS				LGV				MOV	LGV+MOV
	Value	Week Start	Week End	Week Start	Week End	Value	Value	Value	Value	
1	160	70	70	70	70	160	0	309	309	
2	274	158	158	158	158	274	8	52	60	
3	0	0	204	0	204	0	3	0	3	
4	376	162	162	162	162	376	2	0	2	
5	248	83	83	83	83	248	64	222	286	
6	248	83	83	83	83	248	59	222	281	
7	260	162	162	162	162	260	7	75	82	
8	0	0	204	0	204	0	0	0	0	
9	376	162	162	162	162	376	2	0	2	

6.6.6 Importantly, this methodology shows individual peak week construction traffic flows for each receptor, meaning that peaks at each receptor do not necessarily happen in the same week. For example, as seen in **Graphic 6-4** Receptor 1 (Ferry Road) the peak week is Week 70, whilst the peak week for Receptor 7 (A284 North of Wick) is Week 162. This ensures that a worst-case assessment is completed for all identified receptors within the Study Area.

6.6.7 The estimates within this TGTN have been calculated against a conservative set of assumptions based on the best available information on the onshore works within the proposed DCO Order Limits. The final arrangement of the construction works, and precise methods used will be determined during the detailed design stage and the construction phase of the works depending on the working arrangements favoured by the appointed contractor(s). These factors will influence the number of vehicle movements and the personnel requirements.

6.6.8 Based on the methodologies described above for LGVS (staff and deliveries) and HGVS, **Table 6-8** presents the LGV and HGVS peak week movements at each construction access and **Table 6-9** presents the LGV and HGVS movements (two-way total) for each receptor location.

6.6.9 In viewing **Table 6-8** it should be noted that the peak construction traffic week occurs at different accesses during different weeks of the construction programme, and that the HGVS and overall total peaks may be on different weeks. Further details of when the peak construction week occurs at each access, and an estimate of the length of time that construction traffic flows remain above 90%, 75%, and 50% of this peak is included in Annex C.

Table 6-8 Peak weekly movements by access

Access ID	Peak Total Weekly Two-way Movements			
	HGVs		Total vehicles	
	Number	Peak Weeks	Number	Peak Weeks
A-01	160	70	244	70-71
A-02	N/A	N/A	10	N/A
A-03	N/A	N/A	10	N/A
A-05	274	158	1498	72
A-08	N/A	N/A	10	N/A
A-09	232	161	244	161
A-12	234	162	246	162
A-13	130	64	226	64
A-14	N/A	N/A	10	N/A
A-15	All HGV construction traffic routed through A-13		10	N/A
A-16	218	164-166	282	68, 70
A-20	N/A	N/A	10	N/A
A-21	196	161-163	224	61
A-22				
A-24	N/A	N/A	10	N/A
A-25	N/A	N/A	10	N/A
A-26	244	161-166	310	70-73
A-28				
A-33	254	85-87	302	85-87
A-35	76	60, 88	88	60, 88
A-37	N/A	N/A	10	N/A
A-38	N/A	N/A	10	N/A

Access ID	Peak Total Weekly Two-way Movements			
	HGVs		Total vehicles	
	Number	Peak Weeks	Number	Peak Weeks
A-39	266	114-117	1656	83
A-40	160	158-159	222	116
A-41				
A-42	78	106, 161	128	122-123
A-43	236	162-164	248	162-164
A-46	N/A	N/A	10	N/A
A-47	160	157	172	157
A-48	198	158-159	210	158-159
A-49	N/A	N/A	10	N/A
A-50	172	160-161	196	90
A-52	242	162-163	10	N/A
A-53	N/A	N/A	242	162-163
A-56	150	98	198	98
A-57	188	158-159	222	111
A-61	142	160-161	154	160-161
A-62	326	124	866	125
A-63	336	83-90	900	83-90
A-64	274	162	286	162
A-66	N/A	N/A	10	N/A
A-67	170	163	186	125
A-68	92	127-129	272	127-129

Table 6-9 Onshore construction traffic impact per receptor

Link No	Location	Total Peak Week Construction Traffic (per weekday)		HGV Peak Week Construction Traffic (per weekday)	
		Total Vehicles	HGVs	Total Vehicles	HGVs
1	Ferry Road	94	32	94	32
2	Church Lane	367	51	104	55
3	Ford Road	87	0	4	0
4	A27, West of Arundel	88	81	88	81
5	A259, West of Wick	312	45	232	50
6	A284, North of Wick	138	45	132	50
7	A284 Lyminster	138	45	74	52
9	A27, Arundel Station	91	81	91	81
11	A27, South of Crossbush	186	105	128	108
12	A27 High Salvington	128	123	128	123
13	A24/A27 Offington (Warren Road)	128	123	128	123
14	A24 Findon	75	0	2	0
15	A280 Long Furlong	118	108	118	108
16	A283 West of A24	203	51	203	51
17	A283 East of A24	411	12	124	59
18	B2135, South of Ashurst	64	24	42	34
19	A283, Steyning	102	54	90	63
20	A24, South of A272	139	19	120	39

Link No	Location	Total Peak Week Construction Traffic (per weekday)		HGV Peak Week Construction Traffic (per weekday)	
		Total Vehicles	HGVs	Total Vehicles	HGVs
21	B2116 Patridge Green Road	4	0	0	0
22	A281, South Shermanbury	79	48	79	48
23	A281, South of Cowfold	59	0	45	12
24	A281, Cowfold Centre	168	32	155	39
25	A272, Station Road, Cowfold	168	32	155	39
26	Wineham Lane, South of A272	70	41	70	41
27	A272, West of A23	214	85	212	101
28	A23, North of the A272	110	83	110	83
29	B2188, Sayers Common*	0	0	0	0
30	B2116, Henfield Road, Albourne*	0	0	0	0
31	A23, North of the A272	109	93	109	93
32	A27, West of A23	141	95	139	131
33	A27, East of A23	92	47	80	62
34	A259, West of Church Street	76	17	63	18
35	A259, East of Wick	96	0	4	0

6.6.10 **Table 6-10** provides the HGV and LGV movements generated by construction at each of the new receptors identified within [Chapter 32: ES Addendum](#) of the ES (Document Reference: 6.2.32).

Table 6-10 Onshore construction traffic impact per new receptors

Link No	Location	Total Peak Week Construction Traffic (per weekday)		HGV Peak Week Construction Traffic (per weekday)	
		Total Vehicles	HGVs	Total Vehicles	HGVs
A	B2139, Coolham Road	13	0	0	0
B	A272, West Chiltonington Lane, Pound Lane, Shipley Road	13	0	0	0
C	A272, Cowfold Road	168	32	155	39
D	B2135, Steyning Road, East of Park Lane	41	0	1	0
E	A272, Bolney Road, East of A281, North of Oakfield Road	225	32	204	39
F	A272, Cowfold Road West of the A23	214	85	212	101
G	A281, North of Woodside Close	59	0	45	12
H	B2135 / B2116 High Street, Partridge Green	4	0	0	0
I	A281, Brighton Road, North of Partridge Green Road	59	0	45	12
J	Wineham Lane	28	0	0	0
K	B2118, East of B2116 Henfield Road*	0	0	0	0
L	B2135, North of Spithandle Lane	44	6	28	20

Link No	Location	Total Peak Week Construction Traffic (per weekday)		HGV Peak Week Construction Traffic (per weekday)	
		Total Vehicles	HGVs	Total Vehicles	HGVs
M	A281, High Steet, Henfield	64	48	64	48
N	A281, Brighton Road*	0	0	0	0
O	A283 Storrington Road, Northeast of Sullington Lane	203	51	203	51
P	Michelgrove Lane	62	40	51	49
Q	A284, Lyminster Road	138	45	74	52
R	Church Lane, North of the A259	367	51	104	55
S	Ford Road, Station Road*	87	0	4	0
T	Ford Road	87	0	4	0
U	Kent Street**	60	55	60	55

* zero values highlight receptors that were identified but are not anticipated to be used by construction traffic associated with the Proposed Development

** to provide a robust assessment peak week flows for Kent Street have been based upon peak flows associated with construction access A-64.

7. Operation and maintenance traffic generation

7.1 Overview

7.1.1 The operational lifetime of the Proposed Development is expected to be around 30 years. Taking place after commissioning of the Proposed Development, operation and maintenance activities can be divided into three main categories:

- scheduled maintenance;
- unscheduled maintenance; and
- special maintenance in the event of major equipment breakdown and repairs.

7.2 Traffic generation

7.2.1 Maintenance of the onshore cable is expected to be minimal. During operation and maintenance, periodic testing of the cable is likely to be required (every two to five years). This will require access to the link boxes at defined inspection points along the onshore cable route. This will involve attendance by up to three light vehicles, such as vans, in a day at any one location. The vehicles will gain access using existing field accesses and side accesses as agreed with landowners to reach the relevant sections of the onshore cable.

7.2.2 Monitoring of the onshore substation will be done remotely using CCTV technology and other remote monitoring equipment. The security fencing installed during construction will remain in place. Certain areas of the onshore substation will have permanent light fittings; however, these lights will only be used when required for unscheduled maintenance or emergency repair purposes.

7.2.3 Unscheduled maintenance or emergency repair visits will typically involve a very small number of vehicles, typically light vans. Infrequently, equipment may be required to be replaced, then the use of an occasional HGV may be utilised, depending on the nature of the repair.

7.2.4 Inspection and minor servicing may be required for the electrical plant, but it is anticipated that the substation will require minimal scheduled maintenance and operation activities.

7.2.5 Impacts on National Parks from traffic generated from Newhaven Port in Study Area 2 has been considered.

7.2.6 During the operation and maintenance phase, it is currently estimated that 40-50 full time staff will be required per day. For the purposes of assessment in this chapter, it is proposed to assess a worst case of 50 staff per day into and out of East Quay, Newhaven Port, which currently accommodates the existing Rampion 1 project operation and maintenance facility.

- 7.2.7 For the daily traffic generation, it is assumed that all staff arrive by private car with no car sharing or use of sustainable modes. This results in 100 two staff vehicle movements per day, the impacts of which on the local highways network are assessed in of **Chapter 23: Transport, Volume 2** of the ES [APP-064].

7.3 Traffic distribution

- 7.3.1 The traffic is proposed to be distributed following the same approach as staff traffic for the construction phase and using journey to work data. An assessment of journey to work data based on the existing port indicates the following distribution of traffic and where it will leave Study Area 2:
- A259 West (Newhaven) – 30.58%;
 - A259 East – 37.79%;
 - A27 West – 18.64%; and;
 - A27 East – 12.99%.
- 7.3.2 **Figure 23.21a-d, Volume 3** of the ES [APP-064] sets out the daily traffic impacts on the local highways network and the location of the highways links affected is set out in **Figure 23.22, Volume 3** of the ES [APP-064].
- 7.3.3 The impacts on National Parks from operational and maintenance traffic from Newhaven have been considered in Study Area 2.

Table 7-1 Onshore operation and maintenance traffic percentage impact per highways link – Study Area 2

Highway Link	Future Year Base Traffic (2030)		Peak Week Staff Traffic (per day)	
	Total Vehicles	HGVs	Total Vehicles	HGVs
1 - McKinley Road	3055	265	100	0
2 - A26 South Highton	18722	1454	32	0
3 - A26 Beddingham	18722	1454	32	0
4 - A27 West of A26	40726	2205	32	0
5 - A26 East of A25	29199	1257	19	0

8. Decommissioning traffic generation

8.1 Onshore decommissioning

Onshore cable

- 8.1.1 It is anticipated that the onshore electrical cables will be left in-situ with ends cut, sealed and buried to minimise environmental effects associated with removal.
- 8.1.2 The only onshore element of the Proposed Development that will require to be removed in the decommissioning phase is the onshore substation and therefore only a small part of Study Area 1 will be affected by decommissioning traffic.

Onshore substation

- 8.1.3 The onshore substation may be used as a substation site after decommissioning of the Proposed Development or it may be upgraded for use by another offshore wind project. This will be subject to a separate planning application.
- 8.1.4 Should the onshore substation need to be decommissioned fully, however, the decommissioning works are likely to be undertaken in reverse to the sequence of construction works and involve similar levels of equipment. All relevant sites will be restored to their original states or made suitable for an alternative use.
- 8.1.5 The decommissioning duration of the onshore infrastructure may take a comparable amount of time as construction of the Proposed Development, up to four years, although this indicative timing may reduce.
- 8.1.6 The calculations indicate that the peak week of the construction of the onshore substation will result in a peak traffic week that comprises:
- 76 two-way HGV movements during temporary compound construction;
 - 36 two-way LGV movements during temporary compound construction;
 - 2 onshore substation two-way HGV movements;
 - 120 onshore substation two-way HGV movements; and
 - Total two-way vehicle movements: 196 HGV and 38 LGV per week
- 8.1.7 This will result in the following daily traffic which have informed the assessment in [Chapter 23: Transport, Volume 2](#) of the ES [APP-064].
- 39 two-way HGVs; and
 - 8 two-way LGVs.
- 8.1.8 Distribution of this traffic during the decommissioning phase has been based on the same distribution patterns as the construction phase as set out in [Table 6-2](#) and [Table 23-27](#) of the [Chapter 23: Transport, Volume 2](#) of the ES [APP-064].

- 8.1.9 It is considered that the decommissioning of the onshore substation will require the same levels of traffic generation as the construction phase and therefore the peak construction traffic generation of the construction phase will be used as a basis for assessment.
- 8.1.10 Therefore, using Oakendene onshore substation as the basis for assessment and the traffic distribution used for construction. It is considered that only Highway link 27 located on the A272, West of A23 will require assessment for the decommissioning phase, given the logical HGV routes from the SRN.
- 8.1.11 Unlike the assessment for the construction phase, Highways link (27) that requires assessment would only have to accommodate traffic associated with the onshore substation decommissioning and not the traffic associated with the onshore cable decommissioning as the onshore cable will be left in situ. As such traffic at this highways link will be less than set out in the assessment for the construction phase at these two links as the additional cable related traffic in the construction phase would not be present in the decommissioning phase. An assessment has still been provided for robustness due to the different future year for the decommissioning phase.
- 8.1.12 **Table 8-1** shows the anticipated traffic impact during the decommissioning stage, which is de minimis.

Table 8-1 Onshore substation decommissioning traffic percentage impact per highways link

Highway Link	Future Year Base Traffic (2051)		Peak Week Staff Traffic (per day)	
	Total vehicles	HGVs	Total vehicles	HGVs
27 – A272, West of A23	21414	1069	156	48

Offshore

- 8.1.13 The offshore decommissioning phase has been scoped out of further assessment as it is proposed that only above several elements of the Proposed Development are removed such as the offshore substations and WTGs. As such, the onshore traffic generation is expected to be significantly lower than the construction phase.
- 8.1.14 As with the construction phase, the works required to decommission the offshore elements of the Proposed Development are likely to be undertaken from a few ports across Europe and the UK, and as such the impacts on UK roads will be mitigated by this construction strategy. Based on the above, the offshore decommissioning phase has been scoped out of the assessment.

9. Glossary of terms and abbreviations

Term (Acronym)	Definition
AADF	Annual average weekday flow
AAWT	Annual average weekday traffic
CBS	cement bound sand
CMB	construction management base
FOC	Fibre Optic Cable
ha	hectare
HDD	horizontal directional drill
HGV	Heavy Goods Vehicle
HVAC	High Voltage Alternating Current
ID	identification
JB	joint bay
kg	kilogram
Km	kilometre
kV	kilovolt
LGV	Light Goods Vehicle
m	metres
mm	millimetres
Preliminary Environmental Information Report (PEIR)	The written output of the Preliminary Environmental Impact Assessment undertaken for the Proposed Development. It was developed to support Statutory Consultation and presented the preliminary findings of the assessment to allow an informed view

Term (Acronym)	Definition
TCC	to be developed of the Proposed Development, the assessment approach that was undertaken, and the preliminary conclusions on the likely significant effects of the Proposed Development and environmental measures proposed.
TCC	temporary construction compound
TJB	transition joint bay

10. References

CrashMap, (2021). *Crashmap*. [online]. Available at: <https://www.crashmap.co.uk/> [Accessed 4 April 2023].

Department for Transport (DfT), (2022). *DfT Circular 01/2022 Strategic Road Network and the Delivery of Sustainable Development, Page 1-23*. [online]. Available at: [Strategic road network and the delivery of sustainable development - GOV.UK \(www.gov.uk\)](https://www.gov.uk/government/uploads/system/uploads/attachment_data/file/103367/dft-circular-01-2022-strategic-road-network-and-the-delivery-of-sustainable-development.pdf) [Accessed 4 April 2023].

Department for Transport (DfT), (2021). *RAS0302 Reported road collision rates by severity, road type and class, Great Britain, ten years up to 2021* <https://www.gov.uk/government/statistical-data-sets/reported-road-accidents-vehicles-and-casualties-tables-for-great-britain#road-type-ras03> [online]. Available at: [Accessed 4 April 2023].

Department for Transport (DfT), (2020). *Road Traffic Statistics*. [online]. Available at: <https://roadtraffic.dft.gov.uk/#/6/55.254/-6.053/basemap-regions-countpoints> [Accessed 4 April 2023].

Department for Transport (DfT), (2021). *Quarterly traffic estimates (TRA25), TRA2501: Road traffic (vehicle miles) by vehicle type in Great Britain*. [online]. Available at: <https://www.gov.uk/government/statistical-data-sets/tra25-quarterly-estimates> [Accessed 30 June 2021].

Department for Transport (DfT), (2022). *Road Safety Data*. <https://www.data.gov.uk/dataset/cb7ae6f0-4be6-4935-9277-47e5ce24a11f/road-safety-data> [online]. Available at: [Accessed 4 April 2023].

Department of Energy and Climate Change (DECC), (2011). *Overarching National Policy Statement for Energy (EN-1)*. [online]. Available at: https://assets.publishing.service.gov.uk/government/uploads/system/uploads/attachment_data/file/47854/1938-overarching-nps-for-energy-en1.pdf [Accessed 4 April 2023].

E.On/RSK Environmental Ltd, (2012). *Rampion Offshore Wind Farm, Environmental Statement, RSK, Section 29 Transport*. [online]. Available at: <https://www.rampionoffshore.com/environmental-statement/> [Accessed 4 April 2023].

Google, (2021). *Google Maps and Google Traffic*. [online]. Available at <https://www.google.co.uk/maps/> [Accessed 4 April 2023].

Horsham District Local Council, (2019). *Draft Horsham District Local Plan 2019-2036*. [online]. Available at: <https://strategicplanning.horsham.gov.uk/LocalPlanReview/viewCompoundDoc?docid=10336756> [Accessed 4 April 2023].

Institute of Environmental Assessment (IEA), (1993). *Guidance Note 1 – Guidelines for the Environmental Assessment of Road Traffic*.

Mid Sussex District Council, (2018). *Mid Sussex District Plan 2014 – 2031, Pages 78-79*. [online]. Available at: <https://www.midsussex.gov.uk/media/2367/district-plan-adoption-version.pdf> [Accessed 04 April 2023].

Ministry of Housing Communities and Local Government, (2021). *National Planning Policy Framework, pages 31-32*. [online]. Available at: <https://www.gov.uk/government/publications/national-planning-policy-framework--2> [Accessed 04 April 2023].

Office for National Statistics, (2011). *Nomis Official Labour Market Statistics*. [online] Available at <https://www.nomisweb.co.uk/> [Accessed 04 April 2023].

Owen Williams Consultants, (1996). *Newhaven Port Access Road – Site Plan, East Sussex County Council, Drawing 5A928/12/2*. [online]. Available at: <https://www.eastsussex.gov.uk/roadsandtransport/roads/roadschemes/newhaven-port-access-road/scheme-details/> [Accessed 04 April 2023].

Planning Inspectorate (PINS). (2020a). *Scoping Opinion: Proposed Rampion 2 Offshore Wind Farm. Case Reference EN010117*, [online]. Available at: https://infrastructure.planninginspectorate.gov.uk/wp-content/ipc/uploads/projects/EN010117/EN010117-000045-EN010117_Scoping_Opinion.pdf [Accessed 04 April 2023].

Planning Inspectorate, (2020b). *Advice Note Seven: EIA: Process, Preliminary Environmental Information, and Environmental Statements (Version 7)*. [online]. Available at: <https://infrastructure.planninginspectorate.gov.uk/legislation-and-advice/advice-notes/advice-note-seven-environmental-impact-assessment-process-preliminary-environmental-information-and-environmental-statements/> [Accessed 04 April 2023].

Rampion Extension Development Limited (RED), (2020). *Rampion 2 Offshore Wind Farm – Environmental Impact Assessment Scoping Report*, [online]. Available at: <https://infrastructure.planninginspectorate.gov.uk/wp-content/ipc/uploads/projects/EN010117/EN010117-000006-EN010117%20-%20Scoping%20Report.pdf> [Accessed 04 April 2023].

Standards for Highways, (2020). *Design Manual for Roads and Bridges*. [online]. Available at: <https://www.standardsforhighways.co.uk/dmr/b/> [Accessed 04 April 2023].

Sustrans, (2021). *Sustrans National Cycle Network Map*. [online]. Available at: <https://www.sustrans.org.uk/national-cycle-network> [Accessed 04 April 2023].

West Sussex County Council (WSCC), (2022), *West Sussex Transport Plan 2022-2036, Pages 26-29, 35, 44, 50-51*. <https://www.westsussex.gov.uk/media/17428/wstp.pdf> [online]. Available at: [Accessed 04 April 2023].

West Sussex County Council (WSCC), (2020a). *West Sussex Walking and Cycling Strategy 2016-2026, Pages 1-52*. [online]. Available at: https://www.westsussex.gov.uk/media/9584/walking_cycling_strategy.pdf [Accessed 04 April 2023].

West Sussex County Council (WSCC), (2020b). *Permanent Automatic Traffic Counts*. [online]. Available at: <https://www.westsussex.gov.uk/roads-and-travel/traffic-management/traffic-counts/> [Accessed 04 April 2023].

West Sussex County Council (WSCC), (2021a). *iMap*. [online]. Available at: <https://www.westsussex.gov.uk/land-waste-and-housing/public-paths-and-the-countryside/public-rights-of-way/public-rights-of-way-imap/imap/> [Accessed 04 April 2023].

West Sussex County Council (WSCC), (2021b). *Bus routes and timetables*. [online]. Available at: <https://www.westsussex.gov.uk/roads-and-travel/travel-and-public->

[transport/bus-and-coach-travel/plan-your-journey/bus-routes-and-timetables/](#) [Accessed 04 April 2023].

Worthing Borough Council, (2023). *Local Plan 2020 – 2036, Page 149-150*. [online]. Available at: <https://www.adur-worthing.gov.uk/media/Media,169486,smxx.pdf> [Accessed 04 April 2023].



Page intentionally blank

Annex A

Traffic calculations

Page intentionally blank

Peak Week

Receptor Number	Receptor Location	Base Traffic - Historic Counts						Growth Rate to 2021		2021 Base Year of Assessment				Future Assessment Year	Growth Rate to Future Year (2021 - 2026/27)		Future Year of Assessment				Peak Development Traffic				Future Year + Development Peak				Development Traffic % Impact (2026/27)			
		24 Hour		18 Hour		Speed (85th%)	Base Year	Total Vehicles	HGVs	24 Hour		18 Hour			Total Vehicles	HGVs	24 Hour		18 Hour		24 Hour		18 Hour		24 Hour		18 Hour		24 Hour		18 Hour	
		Total	HGV	Total	HGV					Total	HGV	Total	HGV				Total	HGV	Total	HGV	Total	HGV	Total	HGV	Total	HGV	Total	HGV	Total	HGV	Total	HGV
1	Ferry Road	2022 ATC				60.0	2022			1925	314	1907	310	2026	1.0746	1.075	2069	338	2049	334	32	32	0	32	32	2101	370	2081	366	1.5%	9.5%	
2	Church Lane	3859	1106	9644	1072	41.9	2017	1.0607	1.027	10458	1135	10229	1101	2026	1.0746	1.075	11238	1221	10993	1183	137	0	137	137	0	11375	1221	11129	1183	1.2%	0.0%	
3	Ford Road	6025	253	5869	237	25.6	2019	1.0305	1.0075	6209	255	6048	239	2026	1.0746	1.075	6672	274	6499	257	109	32	77	109	32	6782	306	6609	289	1.6%	11.7%	
4	A27 West of Arundel	23618	1302	22781	1159	40	2019	1.0305	1.0075	24338	1312	23476	1167	2026	1.0746	1.075	26154	1410	25228	1255	67	36	31	67	36	26221	1446	25295	1291	0.3%	2.6%	
5	A259 West of Wick	22450	857	11083	809	43	2019	1.0305	1.0075	23083	863	11421	815	2026	1.0746	1.075	24805	928	12273	876	257	23	233	257	23	25062	951	12529	899	1.0%	2.5%	
6	A284 North of Wick	13448	551	12779	490	30	2019	1.0305	1.0075	13652	555	13168	494	2026	1.0746	1.075	14671	597	14151	531	107	23	84	107	23	14778	620	14258	554	0.7%	3.9%	
7	A284 Lyminster	13646	692	13075	651	42	2019	1.0305	1.0075	13959	698	13473	656	2026	1.0746	1.075	15000	750	14478	705	137	53	84	137	53	15138	803	14616	758	0.9%	7.1%	
8	Crossbush Lane, Crossbush	2022 ATC					2019							2026	1.0746	1.075	0	0	0	0	0	0	0	0	0	0	0	0	0	#DIV/0!		
9	A27, Arundel Station	32734	1613	31574	1435	40	2019	1.0305	1.0075	33732	1625	32538	1446	2026	1.0746	1.075	36249	1747	34965	1554	92	51	41	92	51	36341	1798	35057	1605	0.3%	2.9%	
10	Crossbush Lane, Warning Camp	2022 ATC					2022							2026	1.0746	1.075	0	0	0	0	0	0	0	0	0	0	0	0	0	#DIV/0!		
11	A27, South of Crossbush	31836	1757	30805	1563	60	2019	1.0305	1.0075	32910	1770	31744	1575	2026	1.0746	1.075	35365	1903	34112	1693	213	87	126	213	87	35578	1990	34325	1780	0.6%	4.6%	
12	A27 High Salvington	22776	923	21969	821	30	2019	1.0306	1.0075	23473	930	22641	827	2026	1.0788	1.075	25323	1000	24426	890	148	97	51	148	97	25471	1097	24574	987	0.6%	9.7%	
13	A24/A27 Offington (Warren Road)	30777	1012	29687	900	40	2019	1.0306	1.0075	31719	1020	30595	907	2026	1.0788	1.075	34218	1096	33006	975	140	118	22	140	118	34358	1214	33146	1093	0.4%	10.8%	
14	A24 Findon	25751	627	24820	558	40	2018	1.0454	1.016	26899	637	25946	567	2026	1.0788	1.075	29019	685	27991	609	103	21	83	103	21	29122	706	28094	630	0.4%	3.0%	
15	A280 Long Furlong	2022 ATC				40.0	2022			18580	3653	17883	3479	2026	1.0788	1.075	20044	3927	19292	3740	108	34	75	108	34	20152	3960	19400	3774	0.5%	0.9%	
16	A283 West of A24	21977	750	21374	727	41	2019	1.0306	1.0075	22649	755	22028	732	2026	1.0788	1.075	24434	812	23764	787	81	6	75	81	6	24515	818	23845	794	0.3%	0.8%	
17	A283 East of A24	2022 ATC				52.60	2022			11430	2326	11295	2292	2027	1.0868	1.093	12422	2543	12275	2506	182	8	174	182	8	12604	2551	12457	2514	1.5%	0.3%	
19	B2135, South of Ashurst	3444	105	3399	104	48	2019	1.0306	1.0075	3550	106	3502	105	2027	1.0868	1.093	3858	116	3807	115	0	0	0	0	0	3858	116	3807	115	0.0%	0.0%	
20	A283, Steyning	23485	585	20230	570	52	2019	1.0306	1.0075	21112	589	20849	574	2026	1.0788	1.075	22776	633	22491	617	0	0	0	0	0	22776	633	22491	617	0.0%	0.0%	
21	A24, South of A272	35481	1636	33991	1481	40	2019	1.0306	1.0075	36567	1648	35032	1493	2026	1.0788	1.075	39448	1772	37792	1604	93	0	93	93	0	39541	1772	37885	1604	0.2%	0.0%	
22	B2116 Patridge Green Road	6374	362	6264	353	29	2019	1.0306	1.0075	6569	364	6455	355	2027	1.0868	1.093	7140	398	7015	388	22	0	22	22	0	7161	398	7037	388	0.3%	0.0%	
23	A281, South Shermanbury	7730	341	7652	334	40	2018	1.0454	1.016	8090	346	7999	340	2027	1.0868	1.093	8792	378	8693	371	22	0	22	22	0	8814	378	8715	371	0.2%	0.0%	
24	A281, South of Cowfold	6081	141	5866	125	30	2019	1.0306	1.0075	6267	142	6045	126	2027	1.0868	1.093	6811	155	6570	138	0	0	0	0	0	6811	155	6570	138	0.0%	0.0%	
25	A281, Cowfold Center	22369	991	21596	882	30	2019	1.0306	1.0075	23074	998	22257	888	2027	1.0868	1.093	25077	1091	24189	971	106	18	88	106	18	25183	1109	24295	989	0.4%	1.7%	
26	A272, Station Road, Cowfold	18934	745	18305	663	30	2019	1.0306	1.0075	17421	751	16804	668	2027	1.0868	1.093	18933	820	18263	730	101	18	82	101	18	19034	839	18363	748	0.5%	2.2%	
27	Wineham Lane, South of A272	853	16	823	14	60	2019	1.0306	1.0075	879	16	848	14	2026	1.0788	1.075	948	17	915	15	30	12	18	30	12	978	30	945	28	3.2%	71.6%	
29	A272, West of A23	18580	724	16291	644	40	2019	1.0306	1.0075	17406	729	16789	649	2027	1.0868	1.093	18917	797	18247	709	156	48	109	156	48	19073	845	18403	757	0.8%	6.0%	
30	A23, North of the A272	71894	4024	69347	3581	60	2019	1.0306	1.0075	74094	4054	71469	3607	2027	1.0868	1.093	80525	4431	77673	3943	54	18	36	54	18	80579	4449	77727	3961	0.1%	0.4%	
31	B2188, Sayers Common	2022 ATC				37.6	2022			7356	1497	7212	1461	2027	1.0868	1.093	7995	1636	7838	1597	0	0	0	0	0	7995	1636	7838	1597	0.0%	0.0%	
32	B2116, Henfield Road, Albourne	3147	149	3036	133	30	2019	1.0306	1.0075	3243	150	3128	134	2027	1.0868	1.093	3525	164	3400	146	0	0	0	0	0	3525	164	3400	146	0.0%	0.0%	
33	A23, North of the A272	78611	3118	75826	2774	60	2019	1.0306	1.0075	81016	3141	78147	2795	2027	1.0868	1.093	88049	3434	84930	3055	143	90	53	143	90	88192	3523	85073	3145	0.2%	2.6%	
34	A27, West of A23	65068	2421	62763	2154	60	2019	1.0306	1.0075	67059	2439	64684	2170	2027	1.0868	1.093	72880	2666	70298	2372	161	107	55	161	107	73041	2773	70459	2479	0.2%	4.0%	
35	A27, East of A23	71173	2852	68652	2538	60	2019	1.0306	1.0075	73351	2873	70753	2557	2027	1.0868	1.093	79718	3141	76894	2795	76	44	31	76	44	79793	3185	76970	2839	0.1%	1.4%	
36	A259, West of Church Street	25835	548	24920	488	40	2019	1.0305	1.0075	26623	552	25680	491	2026	1.0746	1.075	28609	594	27596	528	38	9	29	38	9	28647	602	27633	537	0.1%	1.5%	
37	A259 East of Wick	24757	469	23880	417	40	2019	1.0305	1.0075	25512	473	24608	420	2026	1.0746	1.075	27415	508	26444	452	85	0	85	85	0	27500	508	26529	452	0.3%	0.0%	

Section 2

Receptor Number	Receptor Location	Base Traffic - Historic Counts					Speed (85th%)	Base Year	Growth Rate to 2021		2021 Base Year of Assessment				Future Assessment Year	Growth Rate to Future Year (2021 - 2026/27)		Future Year of Assessment				Peak Development Traffic			Future Year + Development Peak		Development Traffic % Impact (2026/27)				
		24 Hour		18 Hour		Total			HGVs	Total Vehicles	HGVs	24 Hour		18 Hour		Total	HGV	Total	HGV	Total	HGV	LV	Total	HGV	Total	HGV	Total	HGV			
		Total	HGV	Total	HGV							Total	HGV	Total															HGV	Total	HGV
1	Ferry Road	2022 ATC				60.0	2022			1925	314	1907	310	2026	1.0746	1.075	2069	338	2049	334	0	0	0	0	0	2069	338	2049	334	0.0%	0.0%
2	Church Lane	9893	1106	9644	1072	41.9	2017	1.0607	1.027	10458	1135	10229	1101	2026	1.0746	1.075	11238	1221	10993	1183	0	0	0	0	0	11238	1221	10993	1183	0.0%	0.0%
3	Ford Road	6075	253	5869	237	25.6	2019	1.0305	1.0075	6209	255	6048	239	2026	1.0746	1.075	6672	274	6499	257	0	0	0	0	0	6672	274	6499	257	0.0%	0.0%
4	A27 West of Arundel	23618	1302	22781	1159	40	2019	1.0305	1.0075	24338	1312	23476	1167	2026	1.0746	1.075	26154	1410	25228	1255	7	1	5	7	1	26161	1412	25234	1256	0.0%	0.1%
5	A259 West of Wick	22400	857	11083	809	43	2019	1.0305	1.0075	23083	863	11421	815	2026	1.0746	1.075	24805	928	12273	876	9	0	9	9	0	24815	928	12282	876	0.0%	0.0%
6	A284 North of A24	13248	551	12779	490	30	2019	1.0305	1.0075	13652	555	13168	494	2026	1.0746	1.075	14671	597	14151	531	34	0	34	34	0	14704	597	14184	531	0.2%	0.0%
7	A284 Lyminster	13546	692	13075	651	42	2019	1.0305	1.0075	13959	698	13473	656	2026	1.0746	1.075	15000	750	14478	705	34	0	34	34	0	15034	750	14512	705	0.2%	0.0%
8	Crossbush Lane, Crossbush	2022 ATC					2019							2026	1.0746	1.075	0	0	0	0	0	0	0	0	0	0	0	0	0	0.0%	0.0%
9	A27, Arundel Station	32734	1613	31574	1435	40	2019	1.0305	1.0075	33732	1625	32538	1446	2026	1.0746	1.075	36249	1747	34965	1554	7	1	5	7	1	36256	1748	34972	1556	0.0%	0.1%
10	Crossbush Lane, Warning Camp	2022 ATC					2022							2026	1.0746	1.075	0	0	0	0	0	0	0	0	0	0	0	0	0	0.0%	0.0%
11	A27, South of Crossbush	31936	1757	30805	1563	60	2019	1.0305	1.0075	32910	1770	31744	1575	2026	1.0746	1.075	35365	1903	34112	1693	40	1	39	40	1	35405	1904	34153	1695	0.1%	0.1%
12	A27 High Salvington	22776	923	21969	821	30	2019	1.0306	1.0075	23473	930	22641	827	2026	1.0788	1.075	25323	1000	24426	890	0	0	0	0	0	25323	1000	24426	890	0.0%	0.0%
13	A24/A27 Offington (Warren Road)	30777	1012	29687	900	40	2019	1.0306	1.0075	31719	1020	30595	907	2026	1.0788	1.075	34218	1096	33006	975	4	4	0	4	4	34222	1100	33010	979	0.0%	0.3%
14	A24 Findon	25731	627	24820	558	40	2018	1.0454	1.016	26899	637	25946	567	2026	1.0788	1.075	29019	685	27991	609	65	4	62	65	4	29084	689	28056	613	0.2%	0.5%
15	A280 Long Furlong	2022 ATC				40.0	2022			18580	3653	17883	3479	2026	1.0788	1.075	20044	3927	19292	3740	43	4	39	43	4	20086	3930	19334	3744	0.2%	0.1%
16	A283 West of A24	21977	750	21374	727	41	2019	1.0306	1.0075	22649	755	22028	732	2026	1.0788	1.075	24434	812	23764	787	128	5	123	128	5	24562	817	23891	792	0.5%	0.6%
17	A283 East of A24	2022 ATC				52.60	2022			11430	2326	11295	2292	2027	1.0868	1.093	12422	2543	12275	2506	260	0	260	260	0	12682	2543	12535	2506	2.1%	0.0%
19	B2135, South of Ashurst	3444	105	3399	104	48	2019	1.0306	1.0075	3550	106	3502	105	2027	1.0868	1.093	3858	116	3807	115	0	0	0	0	0	3858	116	3807	115	0.0%	0.0%
20	A283, Steyning	20485	585	20230	570	52	2019	1.0306	1.0075	21112	589	20849	574	2026	1.0788	1.075	22776	633	22491	617	0	0	0	0	0	22776	633	22491	617	0.0%	0.0%
21	A24, South of A272	35481	1636	33991	1481	40	2019	1.0306	1.0075	36567	1648	35032	1493	2026	1.0788	1.075	39448	1772	37792	1604	72	0	72	72	0	39521	1772	37864	1604	0.2%	0.0%
22	B2116 Patridge Green Road	6374	362	6264	353	29	2019	1.0306	1.0075	6569	364	6455	355	2027	1.0868	1.093	7140	398	7015	388	47	12	36	47	12	7187	410	7063	400	0.7%	2.9%
23	A281, South Shermanbury	7739	341	7652	334	40	2018	1.0454	1.016	8090	346	7999	340	2027	1.0868	1.093	8792	378	8693	371	43	7	36	43	7	8835	385	8736	378	0.5%	1.9%
24	A281, South of Cowfold	8081	141	5866	125	30	2019	1.0306	1.0075	6267	142	6045	126	2027	1.0868	1.093	6811	155	6570	138	4	4	0	4	4	6815	160	6574	143	0.1%	2.8%
25	A281, Cowfold Center	22369	991	21596	882	30	2019	1.0306	1.0075	23074	998	22257	888	2027	1.0868	1.093	25077	1091	24189	971	11	0	11	11	0	25088	1091	24199	971	0.0%	0.0%
26	A272, Station Road, Cowfold	16904	745	16305	663	30	2019	1.0306	1.0075	17421	751	16804	668	2027	1.0868	1.093	18933	820	18263	730	11	0	11	11	0	18944	820	18273	730	0.1%	0.0%
27	Wineham Lane, South of A272	853	16	823	14	60	2019	1.0306	1.0075	879	16	848	14	2026	1.0788	1.075	948	17	915	15	0	0	0	0	0	948	17	915	15	0.0%	0.0%
29	A272, West of A23	16889	724	16291	644	40	2019	1.0306	1.0075	17406	729	16789	649	2027	1.0868	1.093	18917	797	18247	709	11	4	7	11	4	18928	802	18258	714	0.1%	0.6%
30	A23, North of the A272	71984	4024	69347	3581	60	2019	1.0306	1.0075	74094	4054	71469	3607	2027	1.0868	1.093	80525	4431	77673	3943	10	4	6	10	4	80536	4436	77683	3947	0.0%	0.1%
31	B2188, Sayers Common	2022 ATC				37.6	2022			7356	1497	7212	1461	2027	1.0868	1.093	7995	1636	7838	1597	0	0	0	0	0	7995	1636	7838	1597	0.0%	0.0%
32	B2116, Henfield Road, Albourne	3147	149	3036	133	30	2019	1.0306	1.0075	3243	150	3128	134	2027	1.0868	1.093	3525	164	3400	146	0	0	0	0	0	3525	164	3400	146	0.0%	0.0%
33	A23, North of the A272	78611	3118	75826	2774	60	2019	1.0306	1.0075	81016	3141	78147	2795	2027	1.0868	1.093	88049	3434	84930	3055	9	6	3	9	6	88057	3440	84938	3061	0.0%	0.2%
34	A27, West of A23	65068	2421	62763	2154	60	2019	1.0306	1.0075	67059	2439	64684	2170	2027	1.0868	1.093	72880	2666	70298	2372	9	4	5	9	4	72889	2670	70307	2376	0.0%	0.1%
35	A27, East of A23	71173	2852	68652	2538	60	2019	1.0306	1.0075	73351	2873	70753	2557	2027	1.0868	1.093	79718	3141	76894	2795	7	4	3	7	4	79725	3145	76901	2799	0.0%	0.1%
36	A259, West of Church Street	25535	548	24920	488	40	2019	1.0305	1.0075	26623	552	25680	491	2026	1.0746	1.075	28609	594	27596	528	9	0	9	9	0	28618	594	27605	528	0.0%	0.0%
37	A259 East of Wick	24757	469	23880	417	40	2019	1.0305	1.0075	25512	473	24608	420	2026	1.0746	1.075	27415	508	26444	452	12	0	12	12	0	27427	508	26456	452	0.0%	0.0%

Section 3

Receptor Number	Receptor Location	Base Traffic - Historic Counts						Base Year	Growth Rate to 2021		2021 Base Year of Assessment				Future Assessment Year	Growth Rate to Future Year (2021 - 2026/27)		Future Year of Assessment				Peak Development Traffic				Future Year + Development Peak				Development Traffic % Impact (2026/27)						
		24 Hour		18 Hour		Speed (85th%)	Total Vehicles		HGVs	Total	HGV	Total	HGV	Total		HGV	Total	HGV	Total	HGV	Total	HGV	Total	HGV	Total	HGV	Total	HGV	Total	HGV						
		Total	HGV	Total	HGV																										Total	HGV	Total	HGV	Total	HGV
1	Ferry Road	2022 ATC				60.0		2022			1925	314	1907	310	2026	1.0746	1.075	2069	338	2049	334	0	0	0	0	0	0	2069	338	2049	334	0.0%	0.0%			
2	Church Lane	9859	1106	9644	1072	41.9		2017	1.0607	1.027	10458	1135	10229	1101	2026	1.0746	1.075	11238	1221	10993	1183	0	0	0	0	0	11238	1221	10993	1183	0.0%	0.0%				
3	Ford Road	6025	253	5869	237	25.6		2019	1.0305	1.0075	6209	255	6048	239	2026	1.0746	1.075	6672	274	6499	257	0	0	0	0	0	6672	274	6499	257	0.0%	0.0%				
4	A27 West of Arundel	23618	1302	22781	1159	40		2019	1.0305	1.0075	24338	1312	23476	1167	2026	1.0746	1.075	26154	1410	25228	1255	32	32	0	32	32	26186	1442	25260	1287	0.1%	2.3%				
5	A259 West of Wick	22420	857	11083	809	43		2019	1.0305	1.0075	23083	863	11421	815	2026	1.0746	1.075	24805	928	12273	876	0	0	0	0	0	24805	928	12273	876	0.0%	0.0%				
6	A284 North of Wick	13248	551	12779	490	30		2019	1.0305	1.0075	13652	555	13168	494	2026	1.0746	1.075	14671	597	14151	531	9	0	9	9	0	14679	597	14160	531	0.1%	0.0%				
7	A284 Lyminster	13548	692	13075	651	42		2019	1.0305	1.0075	13959	698	13473	656	2026	1.0746	1.075	15000	750	14478	705	9	0	9	9	0	15009	750	14487	705	0.1%	0.0%				
8	Crossbush Lane, Crossbush	2022 ATC						2019							2026			0	0	0	0	0	0	0	0	0	0	0	0	0	0	0	0.0%	0.0%		
9	A27, Arundel Station	32734	1613	31574	1435	40		2019	1.0305	1.0075	33732	1625	32538	1446	2026	1.0746	1.075	36249	1747	34965	1554	32	32	0	32	32	36281	1779	34997	1587	0.1%	1.9%				
10	Crossbush Lane, Warning Camp	2022 ATC						2022							2026			0	0	0	0	0	0	0	0	0	0	0	0	0	0	0	0.0%	0.0%		
11	A27, South of Crossbush	31936	1757	30805	1563	60		2019	1.0305	1.0075	32910	1770	31744	1575	2026	1.0746	1.075	35365	1903	34112	1693	41	32	9	41	32	35406	1935	34154	1726	0.1%	1.7%				
12	A27 High Salvington	22776	923	21969	821	30		2019	1.0306	1.0075	23473	930	22641	827	2026	1.0788	1.075	25323	1000	24426	890	0	0	0	0	0	25323	1000	24426	890	0.0%	0.0%				
13	A24/A27 Offington (Warren Road)	30777	1012	29687	900	40		2019	1.0306	1.0075	31719	1020	30595	907	2026	1.0788	1.075	34218	1096	33006	975	0	0	0	0	0	34218	1096	33006	975	0.0%	0.0%				
14	A24 Findon	25731	627	24820	558	40		2018	1.0454	1.016	26899	637	25946	567	2026	1.0788	1.075	29019	685	27991	609	26	0	26	26	0	29045	685	28017	609	0.1%	0.0%				
15	A280 Long Furlong	2022 ATC				40.0		2022			18580	3653	17883	3479	2026	1.0788	1.075	20044	3927	19292	3740	43	34	9	43	34	20067	3961	19335	3774	0.2%	0.9%				
16	A283 West of A24	21977	750	21374	727	41		2019	1.0306	1.0075	22649	755	22028	732	2026	1.0788	1.075	24434	812	23764	787	0	0	0	0	0	24434	812	23764	787	0.0%	0.0%				
17	A283 East of A24	2022 ATC				52.60		2022			11430	2326	11295	2292	2027	1.0868	1.093	12422	2543	12275	2506	23	0	23	23	0	12445	2543	12298	2506	0.2%	0.0%				
19	B2135, South of Ashurst	3444	105	3399	104	48		2019	1.0306	1.0075	3550	106	3502	105	2027	1.0868	1.093	3858	116	3807	115	0	0	0	0	0	3858	116	3807	115	0.0%	0.0%				
20	A283, Steyning	20485	585	20230	570	52		2019	1.0306	1.0075	21112	589	20849	574	2026	1.0788	1.075	22776	633	22491	617	0	0	0	0	0	22776	633	22491	617	0.0%	0.0%				
21	A24, South of A272	35481	1636	33991	1481	40		2019	1.0306	1.0075	36567	1648	35032	1493	2026	1.0788	1.075	39448	1772	37792	1604	90	32	58	90	32	39538	1804	37882	1637	0.2%	1.8%				
22	B2116 Patridge Green Road	6374	362	6264	353	29		2019	1.0306	1.0075	6569	364	6455	355	2027	1.0868	1.093	7140	398	7015	388	4	4	0	4	4	7143	402	7019	392	0.1%	0.9%				
23	A281, South Shermanbury	7739	341	7652	334	40		2018	1.0454	1.016	8090	346	7999	340	2027	1.0868	1.093	8792	378	8693	371	6	6	0	6	6	8798	384	8699	377	0.1%	1.6%				
24	A281, South of Cowfold	6081	141	5866	125	30		2019	1.0306	1.0075	6267	142	6045	126	2027	1.0868	1.093	6811	155	6570	138	4	4	0	4	4	6815	159	6573	142	0.1%	2.3%				
25	A281, Cowfold Center	22388	991	21596	882	30		2019	1.0306	1.0075	23074	998	22257	888	2027	1.0868	1.093	25077	1091	24189	971	159	32	127	159	32	25236	1124	24348	1003	0.6%	3.0%				
26	A272, Station Road, Cowfold	18904	745	18305	663	30		2019	1.0306	1.0075	17421	751	16804	668	2027	1.0868	1.093	18933	820	18263	730	159	32	127	159	32	19093	853	18422	762	0.8%	3.9%				
27	Wineham Lane, South of A272	853	16	823	14	60		2019	1.0306	1.0075	879	16	848	14	2026	1.0788	1.075	948	17	915	15	70	41	29	70	41	1019	59	985	57	7.4%	237.8%				
29	A272, West of A23	16869	724	16291	644	40		2019	1.0306	1.0075	17406	729	16789	649	2027	1.0868	1.093	18917	797	18247	709	254	89	166	254	89	19171	886	18501	798	1.3%	11.1%				
30	A23, North of the A272	71894	4024	69347	3581	60		2019	1.0306	1.0075	74094	4054	71469	3607	2027	1.0868	1.093	80525	4431	77673	3943	85	36	49	85	36	80610	4467	77758	3979	0.1%	0.8%				
31	B2188, Sayers Common	2022 ATC				37.6		2022			7356	1497	7212	1461	2027	1.0868	1.093	7995	1636	7838	1597	0	0	0	0	0	7995	1636	7838	1597	0.0%	0.0%				
32	B2116, Henfield Road, Albourne	3147	149	3036	133	30		2019	1.0306	1.0075	3243	150	3128	134	2027	1.0868	1.093	3525	164	3400	146	0	0	0	0	0	3525	164	3400	146	0.0%	0.0%				
33	A23, North of the A272	78611	3118	75826	2774	60		2019	1.0306	1.0075	81016	3141	78147	2795	2027	1.0868	1.093	88049	3434	84930	3055	92	27	65	92	27	88141	3461	85022	3082	0.1%	0.8%				
34	A27, West of A23	68048	2421	62763	2154	60		2019	1.0306	1.0075	67059	2439	64684	2170	2027	1.0868	1.093	72880	2666	70298	2372	42	0	42	42	0	72922	2666	70340	2372	0.1%	0.0%				
35	A27, East of A23	71173	2852	68652	2538	60		2019	1.0306	1.0075	73351	2873	70753	2557	2027	1.0868	1.093	79718	3141	76894	2795	54	27	27	54	27	79772	3168	76948	2822	0.1%	0.9%				
36	A259, West of Church Street	25835	548	24920	488	40		2019	1.0305	1.0075	26623	552	25680	491	2026	1.0746	1.075	28609	594	27596	528	0	0	0	0	0	28609	594	27596	528	0.0%	0.0%				
37	A259 East of Wick	34757	469	23880	417	40		2019	1.0305	1.0075	25512	473	24608	420	2026	1.0746	1.075	27415	508	26444	452	6	0	6	6	0	27422	508	26450	452	0.0%	0.0%				

Year 1 AAWT

Receptor Number	Receptor Location	Base Traffic - Historic Counts					Growth Rate to 2021	2021 Base Year of Assessment				Future Assessment Year	Growth Rate to Future Year (2021 - 2026/27)		Future Year of Assessment				Peak Development Traffic				Future Year + Development Peak				Development Traffic % Impact (2026/27)							
		24 Hour		18 Hour		Speed (85th%)		Base Year	Total Vehicles	HGVs	24 Hour		18 Hour		24 Hour		18 Hour		24 Hour		18 Hour		24 Hour		18 Hour									
		Total	HGV	Total	HGV						Total		HGV	Total	HGV	Total	HGV	Total	HGV	Total	HGV	Total	HGV	Total	HGV	Total	HGV	Total	HGV					
1	Ferry Road	2022 ATC				60.0	2022			1925	314	1907	310	2026	1.0746	1.075	2069	338	2049	334	0	0	0	0	0	0	0	0	2069	338	2049	334	0.0%	0.0%
2	Church Lane	9859	1106	9644	1072	41.9	2017	1.0607	1.027	10458	1135	10229	1101	2026	1.0746	1.075	11238	1221	10993	1183	8	0	8	8	0	0	11246	1221	11000	1183	0.1%	0.0%		
3	Ford Road	8025	253	5869	237	25.6	2019	1.0305	1.0075	6209	255	6048	239	2026	1.0746	1.075	6672	274	6499	257	10	6	4	10	6	6	682	280	6509	262	0.2%	2.1%		
4	A27 West of Arundel	23618	1302	22781	1159	40	2019	1.0305	1.0075	24338	1312	23476	1167	2026	1.0746	1.075	26154	1410	25228	1255	6	5	2	6	5	6	26160	1415	25234	1260	0.0%	0.3%		
5	A259 West of Wick	22400	857	11083	809	43	2019	1.0305	1.0075	23083	863	11421	815	2026	1.0746	1.075	24805	928	12273	876	14	1	13	14	1	14	24819	929	12286	877	0.1%	0.1%		
6	A284 North of Wick	13248	551	12779	490	30	2019	1.0305	1.0075	13652	555	13168	494	2026	1.0746	1.075	14671	597	14151	531	4	1	4	4	1	4	14675	598	14155	532	0.0%	0.1%		
7	A284 Lyminster	13546	692	13075	651	42	2019	1.0305	1.0075	13959	698	13473	656	2026	1.0746	1.075	15000	750	14478	705	7	4	4	7	4	7	15008	754	14486	708	0.0%	0.5%		
8	Crossbush Lane, Crossbush	2022 ATC					2019							2026			0	0	0	0	0	0	0	0	0	0	0	0	0	0	0	0	#DIV/0!	
9	A27, Arundel Station	32734	1613	31574	1435	40	2019	1.0305	1.0075	33732	1625	32538	1446	2026	1.0746	1.075	36249	1747	34965	1554	10	7	2	10	7	10	36258	1754	34974	1562	0.0%	0.4%		
10	Crossbush Lane, Warning Camp	2022 ATC					2022							2026			0	0	0	0	0	0	0	0	0	0	0	0	0	0	0	0	#DIV/0!	
11	A27, South of Crossbush	31936	1757	30805	1563	60	2019	1.0305	1.0075	32910	1770	31744	1575	2026	1.0746	1.075	35365	1903	34112	1693	15	9	6	15	9	15	35380	1912	34128	1703	0.0%	0.5%		
12	A27 High Salvington	22776	923	21969	821	30	2019	1.0306	1.0075	23473	930	22641	827	2026	1.0788	1.075	25323	1000	24426	890	13	10	3	13	10	13	25335	1009	24438	899	0.0%	1.0%		
13	A24/A27 Offington (Warren Road)	30777	1012	29687	900	40	2019	1.0306	1.0075	31719	1020	30595	907	2026	1.0788	1.075	34218	1096	33006	975	14	12	1	14	12	14	34232	1109	33020	988	0.0%	1.1%		
14	A24 Findon	25731	627	24820	558	40	2018	1.0454	1.016	26899	637	25946	567	2026	1.0788	1.075	29019	685	27991	609	5	3	2	5	3	5	29024	688	27996	612	0.0%	0.4%		
15	A280 Long Furlong	2022 ATC				40.0	2022			18580	3653	17883	3479	2026	1.0788	1.075	20044	3927	19292	3740	4	1	3	4	1	4	20048	3928	19296	3741	0.0%	0.0%		
16	A283 West of A24	21977	750	21374	727	41	2019	1.0306	1.0075	22649	755	22028	732	2026	1.0788	1.075	24434	812	23764	787	1	0	1	1	0	1	24435	812	23765	787	0.0%	0.0%		
17	A283 East of A24	2022 ATC				52.60	2022			11430	2326	11295	2292	2027	1.0868	1.093	12422	2543	12275	2506	6	4	2	6	4	6	12428	2546	12281	2509	0.0%	0.1%		
19	B2135, South of Ashurst	3444	105	3399	104	48	2019	1.0306	1.0075	3550	106	3502	105	2027	1.0868	1.093	3858	116	3807	115	0	0	0	0	0	0	3858	116	3807	115	0.0%	0.0%		
20	A283, Steyning	20485	585	20230	570	52	2019	1.0306	1.0075	21112	589	20849	574	2026	1.0788	1.075	22776	633	22491	617	1	0	1	1	0	1	22776	633	22492	617	0.0%	0.0%		
21	A24, South of A272	35491	1636	33991	1481	40	2019	1.0306	1.0075	36567	1648	35032	1493	2026	1.0788	1.075	39448	1772	37792	1604	2	0	2	2	0	2	39450	1772	37794	1605	0.0%	0.0%		
22	B2116 Patridge Green Road	6374	362	6264	353	29	2019	1.0306	1.0075	6569	364	6455	355	2027	1.0868	1.093	7140	398	7015	388	0	0	0	0	0	0	7140	398	7016	388	0.0%	0.0%		
23	A281, South Shermanbury	7739	341	7652	334	40	2018	1.0454	1.016	8090	346	7999	340	2027	1.0868	1.093	8792	378	8693	371	0	0	0	0	0	0	8793	378	8694	371	0.0%	0.0%		
24	A281, South of Cowfold	8991	141	8866	125	30	2019	1.0306	1.0075	9267	142	9045	126	2027	1.0868	1.093	10111	155	9950	138	0	0	0	0	0	0	10111	155	9950	138	0.0%	0.0%		
25	A281, Cowfold Center	22369	991	21596	882	30	2019	1.0306	1.0075	23074	998	22257	888	2027	1.0868	1.093	25077	1091	24189	971	1	0	1	1	0	1	25078	1092	24190	971	0.0%	0.0%		
26	A272, Station Road, Cowfold	16904	745	16305	663	30	2019	1.0306	1.0075	17421	751	16804	668	2027	1.0868	1.093	18933	820	18263	730	1	0	1	1	0	1	18934	821	18264	730	0.0%	0.0%		
27	Wineham Lane, South of A272	853	16	823	14	60	2019	1.0306	1.0075	879	16	848	14	2026	1.0788	1.075	948	17	915	15	0	0	0	0	0	0	949	17	915	15	0.0%	0.0%		
29	A272, West of A23	18989	724	18291	644	40	2019	1.0306	1.0075	19406	729	18789	649	2027	1.0868	1.093	21000	797	20247	709	2	1	1	2	1	2	21001	798	20248	710	0.0%	0.1%		
30	A23, North of the A272	71894	4024	69347	3581	60	2019	1.0306	1.0075	74094	4054	71469	3607	2027	1.0868	1.093	80525	4431	77673	3943	1	0	0	1	0	1	80526	4432	77674	3943	0.0%	0.0%		
31	B2188, Sayers Common	2022 ATC				37.6	2022			7356	1497	7212	1461	2027	1.0868	1.093	7995	1636	7838	1597	0	0	0	0	0	0	7995	1636	7838	1597	0.0%	0.0%		
32	B2116, Henfield Road, Albourne	3147	149	3036	133	30	2019	1.0306	1.0075	3243	150	3128	134	2027	1.0868	1.093	3525	164	3400	146	0	0	0	0	0	0	3525	164	3400	146	0.0%	0.0%		
33	A23, North of the A272	79611	3118	75826	2774	60	2019	1.0306	1.0075	81016	3141	78147	2795	2027	1.0868	1.093	88049	3434	84930	3055	10	9	1	10	9	10	88059	3443	84940	3064	0.0%	0.3%		
34	A27, West of A23	65068	2421	62763	2154	60	2019	1.0306	1.0075	67059	2439	64684	2170	2027	1.0868	1.093	72880	2666	70298	2372	14	12	2	14	12	14	72894	2678	70312	2385	0.0%	0.5%		
35	A27, East of A23	71173	2852	68652	2538	60	2019	1.0306	1.0075	73351	2873	70753	2557	2027	1.0868	1.093	79718	3141	76894	2795	5	4	1	5	4	5	79722	3144	76899	2798	0.0%	0.1%		
36	A259, West of Church Street	25835	548	24920	488	40	2019	1.0305	1.0075	26623	552	25680	491	2026	1.0746	1.075	28609	594	27596	528	2	0	1	2	0	2	28611	594	27597	528	0.0%	0.0%		
37	A259 East of Wick	24757	469	23880	417	40	2019	1.0305	1.0075	25512	473	24608	420	2026	1.0746	1.075	27415	508	26444	452	4	0	4	4	0	4	27420	508	26449	452	0.0%	0.0%		

Year 2 AAWT

Receptor Number	Receptor Location	Base Traffic - Historic Counts						Base Year	Growth Rate to 2021		2021 Base Year of Assessment				Future Assessment Year	Growth Rate to Future Year (2021 - 2026/27)		Future Year of Assessment				Peak Development Traffic				Future Year + Development Peak		Development Traffic % Impact (2026/27)				
		24 Hour		18 Hour		Speed (85th%)	Total Vehicles		HGVs	24 Hour		18 Hour		24 Hour		18 Hour		24 Hour		18 Hour		24 Hour		Total	HGV							
		Total	HGV	Total	HGV					Total	HGV	Total	HGV	Total		HGV	Total	HGV	Total	HGV	Total	HGV	Total			HGV	Total	HGV				
1	Ferry Road	2022 ATC				60.0	2022			1925	314	1907	310	2026	1.0746	1.075	2069	338	2049	334	7	7	0	7	7	0	11313	1221	11067	1183	0.3%	2.0%
2	Church Lane	9859	1106	9644	1072	41.9	2017	1.0607	1.027	10458	1135	10229	1101	2026	1.0746	1.075	11238	1221	10993	1183	75	0	75	75	0	11313	1221	11067	1183	0.7%	0.0%	
3	Ford Road	6025	253	5869	237	25.6	2019	1.0305	1.0075	6209	255	6048	239	2026	1.0746	1.075	6672	274	6499	257	67	25	42	67	25	6740	299	6567	282	1.0%	9.2%	
4	A27 West of Arundel	23618	1302	22781	1159	40	2019	1.0305	1.0075	24338	1312	23476	1167	2026	1.0746	1.075	26154	1410	25228	1255	51	34	18	51	34	26205	1444	25279	1288	0.2%	2.4%	
5	A259 West of Wick	22490	857	11083	809	43	2019	1.0305	1.0075	23083	863	11421	815	2026	1.0746	1.075	24805	928	12273	876	136	7	129	136	7	24941	935	12409	884	0.5%	0.8%	
6	A284 North of Wick	13248	551	12779	490	30	2019	1.0305	1.0075	13652	555	13168	494	2026	1.0746	1.075	14671	597	14151	531	59	7	51	59	7	14729	604	14210	538	0.4%	1.2%	
7	A284 Lyminster	13548	692	13075	651	42	2019	1.0305	1.0075	13959	698	13473	656	2026	1.0746	1.075	15000	750	14478	705	77	26	51	77	26	15078	776	14556	731	0.5%	3.4%	
8	Crossbush Lane, Crossbush	2022 ATC				40	2019							2026	1.0746	1.075	0	0	0	0	0	0	0	0	0	0	0	0	0	0	#DIV/0!	
9	A27, Arundel Station	32734	1613	31574	1435	40	2019	1.0305	1.0075	33732	1625	32538	1446	2026	1.0746	1.075	36249	1747	34965	1554	68	45	23	68	45	36317	1792	35033	1599	0.2%	2.6%	
10	Crossbush Lane, Warning Camp	2022 ATC				40	2022							2026	1.0746	1.075	0	0	0	0	0	0	0	0	0	0	0	0	0	0	#DIV/0!	
11	A27, South of Crossbush	31936	1757	30805	1563	60	2019	1.0305	1.0075	32910	1770	31744	1575	2026	1.0746	1.075	35365	1903	34112	1693	135	61	75	135	61	35501	1964	34248	1754	0.4%	3.2%	
12	A27 High Salvington	22776	923	21969	821	30	2019	1.0306	1.0075	23473	930	22641	827	2026	1.0788	1.075	25323	1000	24426	890	77	49	28	77	49	25400	1049	24503	939	0.3%	4.9%	
13	A24/A27 Offington (Warren Road)	30777	1012	29687	900	40	2019	1.0306	1.0075	31719	1020	30595	907	2026	1.0788	1.075	34218	1096	33006	975	76	64	12	76	64	34294	1160	33082	1040	0.2%	5.9%	
14	A24 Findon	25731	627	24820	558	40	2018	1.0454	1.016	26899	637	25946	567	2026	1.0788	1.075	29019	685	27991	609	71	15	56	71	15	29090	700	28062	624	0.2%	2.2%	
15	A280 Long Furlong	2022 ATC				40.0	2022			18580	3653	17883	3479	2026	1.0788	1.075	20044	3927	19292	3740	76	29	47	76	29	20119	3955	19367	3769	0.4%	0.7%	
16	A283 West of A24	21977	750	21374	727	41	2019	1.0306	1.0075	22649	755	22028	732	2026	1.0788	1.075	24434	812	23764	787	70	12	58	70	12	24504	824	23833	799	0.3%	1.5%	
17	A283 East of A24	2022 ATC				52.60	2022			11430	2326	11295	2292	2027	1.0868	1.093	12422	2543	12275	2506	142	9	133	142	9	12565	2551	12417	2514	1.1%	0.3%	
19	B2135, South of Ashurst	3444	105	3399	104	48	2019	1.0306	1.0075	3550	106	3502	105	2027	1.0868	1.093	3858	116	3807	115	5	5	0	5	5	3862	120	3811	119	0.1%	4.1%	
20	A283, Steyning	20485	585	20230	570	52	2019	1.0306	1.0075	21112	589	20849	574	2026	1.0788	1.075	22776	633	22491	617	44	0	44	44	0	22820	633	22536	617	0.2%	0.0%	
21	A24, South of A272	35481	1636	33991	1481	40	2019	1.0306	1.0075	36567	1648	35032	1493	2026	1.0788	1.075	39448	1772	37792	1604	78	12	66	78	12	39526	1784	37870	1616	0.2%	0.7%	
22	B2116 Patridge Green Road	6374	362	6264	353	29	2019	1.0306	1.0075	6569	364	6455	355	2027	1.0868	1.093	7140	398	7015	388	23	6	17	23	6	7163	405	7039	395	0.3%	1.6%	
23	A281, South Shermanbury	7739	341	7652	334	40	2018	1.0454	1.016	8090	346	7999	340	2027	1.0868	1.093	8792	378	8693	371	23	6	17	23	6	8815	384	8716	377	0.3%	1.5%	
24	A281, South of Cowfold	6091	141	5866	125	30	2019	1.0306	1.0075	6267	142	6045	126	2027	1.0868	1.093	6811	155	6570	138	4	4	0	4	4	6815	159	6573	142	0.1%	2.3%	
25	A281, Cowfold Center	22389	991	21596	882	30	2019	1.0306	1.0075	23074	998	22257	888	2027	1.0868	1.093	25077	1091	24189	971	72	12	60	72	12	25149	1103	24261	983	0.3%	1.1%	
26	A272, Station Road, Cowfold	18904	745	18305	663	30	2019	1.0306	1.0075	17421	751	16804	668	2027	1.0868	1.093	18933	820	18263	730	69	12	57	69	12	19003	832	18332	742	0.4%	1.5%	
27	Wineham Lane, South of A272	853	16	823	14	60	2019	1.0306	1.0075	879	16	848	14	2026	1.0788	1.075	948	17	915	15	3	1	3	3	1	952	18	918	16	0.4%	3.5%	
29	A272, West of A23	10869	724	10291	644	40	2019	1.0306	1.0075	17406	729	16789	649	2027	1.0868	1.093	18917	797	18247	709	109	35	74	109	35	19026	832	18356	745	0.6%	4.4%	
30	A23, North of the A272	71894	4024	69347	3581	60	2019	1.0306	1.0075	74094	4054	71469	3607	2027	1.0868	1.093	80525	4431	77673	3943	40	16	24	40	16	80565	4447	77713	3959	0.0%	0.4%	
31	B2188, Sayers Common	2022 ATC				37.6	2022			7356	1497	7212	1461	2027	1.0868	1.093	7995	1636	7838	1597	0	0	0	0	0	7995	1636	7838	1597	0.0%	0.0%	
32	B2116, Henfield Road, Albourne	3147	149	3036	133	30	2019	1.0306	1.0075	3243	150	3128	134	2027	1.0868	1.093	3525	164	3400	146	0	0	0	0	0	3525	164	3400	146	0.0%	0.0%	
33	A23, North of the A272	78611	3118	75826	2774	60	2019	1.0306	1.0075	81016	3141	78147	2795	2027	1.0868	1.093	88049	3434	84930	3055	90	56	34	90	56	88139	3489	85020	3111	0.1%	1.6%	
34	A27, West of A23	68008	2421	62763	2154	60	2019	1.0306	1.0075	67059	2439	64684	2170	2027	1.0868	1.093	72880	2666	70298	2372	95	62	33	95	62	72974	2728	70393	2434	0.1%	2.3%	
35	A27, East of A23	71173	2852	68652	2538	60	2019	1.0306	1.0075	73351	2873	70753	2567	2027	1.0868	1.093	79718	3141	76894	2795	48	29	19	48	29	79766	3170	76942	2824	0.1%	0.9%	
36	A259, West of Church Street	25835	548	24920	488	40	2019	1.0305	1.0075	26623	552	25680	491	2026	1.0746	1.075	28609	594	27596	528	20	3	17	20	3	28629	596	27616	531	0.1%	0.5%	
37	A259 East of Wick	34757	469	23880	417	40	2019	1.0305	1.0075	25512	473	24608	420	2026	1.0746	1.075	27415	508	26444	452	49	0	49	49	0	27464	508	26493	452	0.2%	0.0%	

Year 3 AAWT

Receptor Number	Receptor Location	Base Traffic - Historic Counts						Base Year	Growth Rate to 2021		2021 Base Year of Assessment				Future Assessment Year	Growth Rate to Future Year (2021 - 2026/27)		Future Year of Assessment				Peak Development Traffic				Future Year + Development Peak				Development Traffic % Impact (2026/27)		
		24 Hour		18 Hour		Speed (85th%)	Total Vehicles		HGVs	24 Hour		18 Hour		24 Hour		18 Hour		24 Hour		18 Hour		24 Hour		18 Hour		24 Hour						
		Total	HGV	Total	HGV					Total	HGV	Total	HGV	Total		HGV	Total	HGV	Total	HGV	Total	HGV	Total	HGV	Total	HGV	Total	HGV	Total	HGV		
1	Ferry Road	2022 ATC				60.0	2022			1925	314	1907	310	2026	1.0746	1.075	2069	338	2049	334	0	0	0	0	0	0	2069	338	2049	334	0.0%	0.1%
2	Church Lane	9859	1106	9644	1072	41.9	2017	1.0607	1.027	10458	1135	10229	1101	2026	1.0746	1.075	11238	1221	10993	1183	1	0	1	1	0	11239	1221	10994	1183	0.0%	0.0%	
3	Ford Road	6025	253	5869	237	25.6	2019	1.0305	1.0075	6209	255	6048	239	2026	1.0746	1.075	6672	274	6499	257	6	6	1	6	6	6679	280	6505	262	0.1%	2.1%	
4	A27 West of Arundel	23618	1302	22781	1159	40	2019	1.0305	1.0075	24338	1312	23476	1167	2026	1.0746	1.075	26154	1410	25228	1255	24	22	1	24	22	26178	1432	25251	1277	0.1%	1.6%	
5	A259 West of Wick	22490	857	11083	809	43	2019	1.0305	1.0075	23083	863	11421	815	2026	1.0746	1.075	24805	928	12273	876	4	0	4	4	0	24810	928	12277	876	0.0%	0.0%	
6	A284 North of Wick	13248	551	12779	490	30	2019	1.0305	1.0075	13652	555	13168	494	2026	1.0746	1.075	14671	597	14151	531	14	0	13	14	0	14684	597	14165	531	0.1%	0.0%	
7	A284 Lyminster	13548	692	13075	651	42	2019	1.0305	1.0075	13959	698	13473	656	2026	1.0746	1.075	15000	750	14478	705	14	0	13	14	0	15014	750	14492	705	0.1%	0.0%	
8	Crossbush Lane, Crossbush	2022 ATC				40	2019							2026			0	0	0	0	0	0	0	0	0	0	0	0	0	#DIV/0!		
9	A27, Arundel Station	32734	1613	31574	1435	40	2019	1.0305	1.0075	33732	1625	32538	1446	2026	1.0746	1.075	36249	1747	34965	1554	26	25	2	26	25	36275	1772	34991	1579	0.1%	1.4%	
10	Crossbush Lane, Warning Camp	2022 ATC				40	2022							2026			0	0	0	0	0	0	0	0	0	0	0	0	#DIV/0!			
11	A27, South of Crossbush	31936	1757	30805	1563	60	2019	1.0305	1.0075	32910	1770	31744	1575	2026	1.0746	1.075	35365	1903	34112	1693	40	25	15	40	25	35405	1928	34152	1718	0.1%	1.3%	
12	A27 High Salvington	22776	923	21969	821	30	2019	1.0306	1.0075	23473	930	22641	827	2026	1.0788	1.075	25323	1000	24426	890	5	4	0	5	4	25327	1004	24430	894	0.0%	0.4%	
13	A24/A27 Offington (Warren Road)	30777	1012	29687	900	40	2019	1.0306	1.0075	31719	1020	30595	907	2026	1.0788	1.075	34218	1096	33006	975	30	30	0	30	30	34248	1126	33036	1005	0.1%	2.7%	
14	A24 Findon	25731	627	24820	558	40	2018	1.0454	1.016	26899	637	25946	567	2026	1.0788	1.075	29019	685	27991	609	56	25	30	56	25	29074	710	28047	635	0.2%	3.7%	
15	A280 Long Furlong	2022 ATC				40.0	2022			18580	3653	17883	3479	2026	1.0788	1.075	20044	3927	19292	3740	37	22	15	37	22	20081	3949	19329	3762	0.2%	0.6%	
16	A283 West of A24	21977	750	21374	727	41	2019	1.0306	1.0075	22649	755	22028	732	2026	1.0788	1.075	24434	812	23764	787	29	0	29	29	0	24463	812	23792	787	0.1%	0.0%	
17	A283 East of A24	2022 ATC				52.60	2022			11430	2326	11295	2292	2027	1.0868	1.093	12422	2543	12275	2506	109	35	74	109	35	12531	2578	12384	2541	0.9%	1.4%	
19	B2135, South of Ashurst	3444	105	3399	104	48	2019	1.0306	1.0075	3550	106	3502	105	2027	1.0868	1.093	3858	116	3807	115	4	4	4	4	4	3862	120	3811	119	0.1%	3.9%	
20	A283, Steyning	20485	585	20230	570	52	2019	1.0306	1.0075	21112	589	20849	574	2026	1.0788	1.075	22776	633	22491	617	22	0	22	22	0	22798	633	22513	617	0.1%	0.0%	
21	A24, South of A272	35481	1636	33991	1481	40	2019	1.0306	1.0075	36567	1648	35032	1493	2026	1.0788	1.075	39448	1772	37792	1604	62	11	51	62	11	39510	1783	37854	1615	0.2%	0.6%	
22	B2116 Patridge Green Road	6374	362	6264	353	29	2019	1.0306	1.0075	6569	364	6455	355	2027	1.0868	1.093	7140	398	7015	388	14	6	8	14	6	7154	404	7030	394	0.2%	1.5%	
23	A281, South Shermanbury	7739	341	7652	334	40	2018	1.0454	1.016	8090	346	7999	340	2027	1.0868	1.093	8792	378	8693	371	14	5	8	14	5	8806	384	8707	376	0.2%	1.4%	
24	A281, South of Cowfold	6091	141	5866	125	30	2019	1.0306	1.0075	6267	142	6045	126	2027	1.0868	1.093	6811	155	6570	138	3	3	0	3	3	6814	159	6573	141	0.0%	2.1%	
25	A281, Cowfold Center	22389	991	21596	882	30	2019	1.0306	1.0075	23074	998	22257	888	2027	1.0868	1.093	25077	1091	24189	971	89	11	78	89	11	25166	1102	24278	982	0.4%	1.0%	
26	A272, Station Road, Cowfold	18904	745	18305	663	30	2019	1.0306	1.0075	17421	751	16804	668	2027	1.0868	1.093	18933	820	18263	730	89	11	78	89	11	19022	831	18352	741	0.5%	1.3%	
27	Wineham Lane, South of A272	853	16	823	14	60	2019	1.0306	1.0075	879	16	848	14	2026	1.0788	1.075	948	17	915	15	15	5	10	15	5	964	23	930	21	1.6%	39.4%	
29	A272, West of A23	16869	724	16291	644	40	2019	1.0306	1.0075	17406	729	16789	649	2027	1.0868	1.093	18917	797	18247	709	129	29	100	129	29	19046	826	18376	739	0.7%	3.7%	
30	A23, North of the A272	71894	4024	69347	3581	60	2019	1.0306	1.0075	74094	4054	71469	3607	2027	1.0868	1.093	80525	4431	77673	3943	45	14	31	45	14	80570	4445	77718	3957	0.1%	0.3%	
31	B2188, Sayers Common	2022 ATC				37.6	2022			7356	1497	7212	1461	2027	1.0868	1.093	7995	1636	7838	1597	0	0	0	0	0	7995	1636	7838	1597	0.0%	0.0%	
32	B2116, Henfield Road, Albourne	3147	149	3036	133	30	2019	1.0306	1.0075	3243	150	3128	134	2027	1.0868	1.093	3525	164	3400	146	0	0	0	0	0	3525	164	3400	146	0.0%	0.0%	
33	A23, North of the A272	78611	3118	75826	2774	60	2019	1.0306	1.0075	81016	3141	78147	2795	2027	1.0868	1.093	88049	3434	84930	3055	71	32	39	71	32	88119	3465	85000	3087	0.1%	0.9%	
34	A27, West of A23	66048	2421	62763	2154	60	2019	1.0306	1.0075	67059	2439	64684	2170	2027	1.0868	1.093	72880	2666	70298	2372	55	30	25	55	30	72935	2696	70353	2402	0.1%	1.1%	
35	A27, East of A23	71173	2852	68652	2538	60	2019	1.0306	1.0075	73351	2873	70753	2567	2027	1.0868	1.093	79718	3141	76894	2795	36	19	16	36	19	79753	3160	76930	2814	0.0%	0.6%	
36	A259, West of Church Street	25835	548	24920	488	40	2019	1.0305	1.0075	26623	552	25680	491	2026	1.0746	1.075	28609	594	27596	528	2	0	2	2	0	28612	594	27598	528	0.0%	0.0%	
37	A259 East of Wick	24757	469	23880	417	40	2019	1.0305	1.0075	25512	473	24608	420	2026	1.0746	1.075	27415	508	26444	452	7	0	7	7	0	27422	508	26451	452	0.0%	0.0%	

Year 4 AAWT

Receptor Number	Receptor Location	Base Traffic - Historic Counts						Growth Rate to 2021	2021 Base Year of Assessment				Future Assessment Year	Growth Rate to Future Year (2021 - 2026/27)		Future Year of Assessment				Peak Development Traffic				Future Year + Development Peak				Development Traffic % Impact (2026/27)					
		24 Hour		18 Hour		Speed (85th%)	Base Year		Total Vehicles	HGVs	24 Hour			18 Hour		Total Vehicles	HGVs	24 Hour		18 Hour		24 Hour		18 Hour		24 Hour		Total	HGV				
		Total	HGV	Total	HGV						Total	HGV		Total	HGV			Total	HGV	Total	HGV	Total	HGV	Total	HGV	Total	HGV			Total	HGV	Total	HGV
1	Ferry Road	2022 ATC						60.0	2022	1925	314	1907	310	2026	1.0746	1.075	2069	338	2049	334	1	1	0	1	1	2070	338	2049	334	0.0%	0.2%		
2	Church Lane	9839	1106	9644	1072	41.9	2017	1.0607	1.027	10458	1135	10229	1101	2026	1.0746	1.075	11238	1221	10993	1183	4	0	4	4	0	11242	1221	10997	1183	0.0%	0.0%		
3	Ford Road	8625	253	5869	237	25.6	2019	1.0305	1.0075	6209	255	6048	239	2026	1.0746	1.075	6672	274	6499	257	5	3	2	5	3	6678	277	6505	260	0.1%	1.1%		
4	A27 West of Arundel	23619	1302	22781	1159	40	2019	1.0305	1.0075	24338	1312	23476	1167	2026	1.0746	1.075	26154	1410	25228	1255	8	7	1	8	7	26162	1417	25236	1262	0.0%	0.5%		
5	A259 West of Wick	22400	857	11083	809	43	2019	1.0305	1.0075	23083	863	11421	815	2026	1.0746	1.075	24805	928	12273	876	8	1	7	8	1	24814	929	12281	877	0.0%	0.1%		
6	A284 North of Wick	13248	551	12779	490	30	2019	1.0305	1.0075	13652	555	13168	494	2026	1.0746	1.075	14671	597	14151	531	5	1	4	5	1	14676	598	14156	532	0.0%	0.2%		
7	A284 Lyminster	13548	692	13075	651	42	2019	1.0305	1.0075	13959	698	13473	656	2026	1.0746	1.075	15000	750	14478	705	10	6	4	10	6	15010	756	14488	711	0.1%	0.8%		
8	Crossbush Lane, Crossbush	2022 ATC						40.0	2022	0	0	0	0	2026	1.0746	1.075	0	0	0	0	0	0	0	0	0	0	0	0	0	0	0	#DIV/0!	0.0%
9	A27, Arundel Station	32734	1613	31574	1435	40	2019	1.0305	1.0075	33732	1625	32538	1446	2026	1.0746	1.075	36249	1747	34965	1554	10	9	1	10	9	36259	1756	34975	1563	0.0%	0.5%		
10	Crossbush Lane, Warring Camp	2022 ATC						2022	0	0	0	0	2026	1.0746	1.075	0	0	0	0	0	0	0	0	0	0	0	0	0	0	0	0	#DIV/0!	0.0%
11	A27, South of Crossbush	31836	1757	30805	1563	60	2019	1.0305	1.0075	32910	1770	31744	1575	2026	1.0746	1.075	35365	1903	34112	1693	17	12	5	17	12	35382	1915	34129	1705	0.0%	0.6%		
12	A27 High Salvington	22776	923	21969	821	30	2019	1.0306	1.0075	23473	930	22641	827	2026	1.0788	1.075	25323	1000	24426	890	15	13	2	15	13	25337	1013	24440	903	0.1%	1.3%		
13	A24/A27 Offington (Warren Road)	30772	1012	29687	900	40	2019	1.0306	1.0075	31719	1020	30695	907	2026	1.0788	1.075	34218	1096	33006	975	18	17	1	18	17	34236	1113	33024	992	0.1%	1.5%		
14	A24 Findon	25731	627	24820	558	40	2018	1.0454	1.016	26899	637	25946	567	2026	1.0788	1.075	29019	685	27991	609	10	4	7	10	4	29029	689	28001	613	0.0%	0.6%		
15	A280 Long Furlong	2022 ATC						40.0	2022	18580	3653	17883	3479	2026	1.0788	1.075	20044	3927	19292	3740	11	8	4	11	8	20055	3935	19303	3748	0.1%	0.2%		
16	A283 West of A24	21977	750	21374	727	41	2019	1.0306	1.0075	22649	755	22028	732	2026	1.0788	1.075	24434	812	23764	787	2	0	2	2	0	24436	812	23765	787	0.0%	0.0%		
17	A283 East of A24	2022 ATC						52.60	2022	11430	2326	11295	2292	2027	1.0868	1.093	12422	2543	12275	2506	13	5	8	13	5	12435	2548	12288	2511	0.1%	0.2%		
19	B2135, South of Ashurst	3444	105	3399	104	48	2019	1.0306	1.0075	3550	106	3502	105	2027	1.0868	1.093	3858	116	3807	115	3	3	0	3	3	3860	118	3809	117	0.1%	2.3%		
20	A283, Steyning	20495	585	20230	570	52	2019	1.0306	1.0075	21112	589	20849	574	2026	1.0788	1.075	22776	633	22491	617	1	0	1	1	0	22777	633	22493	617	0.0%	0.0%		
21	A24, South of A272	35481	1636	33991	1481	40	2019	1.0306	1.0075	36567	1648	35032	1493	2026	1.0788	1.075	39448	1772	37792	1604	13	1	12	13	1	39461	1773	37805	1606	0.0%	0.1%		
22	B2116 Patridge Green Road	6374	362	6264	353	29	2019	1.0306	1.0075	6569	364	6455	355	2027	1.0868	1.093	7140	398	7015	388	5	4	0	5	4	7144	402	7020	392	0.1%	1.0%		
23	A281, South Shermanbury	7739	341	7652	334	40	2018	1.0454	1.016	8090	346	7999	340	2027	1.0868	1.093	8792	378	8693	371	4	4	0	4	4	8797	382	8698	375	0.1%	1.0%		
24	A281, South of Cowfold	6081	141	5866	125	30	2019	1.0306	1.0075	6267	142	6045	126	2027	1.0868	1.093	6811	155	6670	138	2	2	0	2	2	6813	158	6572	141	0.0%	1.5%		
25	A281, Cowfold Center	22388	991	21596	882	30	2019	1.0306	1.0075	23074	998	22257	888	2027	1.0868	1.093	25077	1091	24189	971	25	1	24	25	1	25102	1092	24214	972	0.1%	0.1%		
26	A272, Station Road, Cowfold	18924	745	18305	663	30	2019	1.0306	1.0075	17421	751	16804	668	2027	1.0868	1.093	18933	820	18263	730	25	1	24	25	1	18958	822	18288	731	0.1%	0.1%		
27	Wineham Lane, South of A272	853	16	823	14	60	2019	1.0306	1.0075	879	16	848	14	2026	1.0788	1.075	948	17	915	15	2	1	1	2	1	950	18	917	16	0.2%	5.3%		
29	A272, West of A23	18899	724	18291	644	40	2019	1.0306	1.0075	17406	729	16789	649	2027	1.0868	1.093	18917	797	18247	709	36	5	31	36	5	18953	803	18283	715	0.2%	0.7%		
30	A23, North of the A272	71898	4024	69347	3581	60	2019	1.0306	1.0075	74094	4054	71469	3607	2027	1.0868	1.093	80525	4431	77673	3943	13	4	9	13	4	80538	4435	77686	3947	0.0%	0.1%		
31	B2188, Sayers Common	2022 ATC						37.6	2022	7356	1497	7212	1461	2027	1.0868	1.093	7995	1636	7838	1597	0	0	0	0	0	7995	1636	7838	1597	0.0%	0.0%		
32	B2116, Henfield Road, Albourne	3147	149	3036	133	30	2019	1.0306	1.0075	3243	150	3128	134	2027	1.0868	1.093	3525	164	3400	146	0	0	0	0	0	3525	164	3400	146	0.0%	0.0%		
33	A23, North of the A272	79511	3118	75826	2774	60	2019	1.0306	1.0075	81016	3141	78147	2795	2027	1.0868	1.093	88049	3434	84930	3055	27	15	12	27	15	88075	3448	84957	3070	0.0%	0.4%		
34	A27, West of A23	65298	2421	62763	2154	60	2019	1.0306	1.0075	67059	2439	64684	2170	2027	1.0868	1.093	72880	2666	70298	2372	25	17	8	25	17	72904	2683	70323	2389	0.0%	0.6%		
35	A27, East of A23	71173	2852	68652	2538	60	2019	1.0306	1.0075	73351	2873	70753	2557	2027	1.0868	1.093	79718	3141	76894	2795	13	7	5	13	7	79730	3148	76907	2802	0.0%	0.2%		
36	A259, West of Church Street	25825	548	24920	488	40	2019	1.0305	1.0075	26623	552	25680	491	2026	1.0746	1.075	28609	594	27596	528	1	0	1	1	0	28610	594	27597	529	0.0%	0.1%		
37	A259 East of Wick	24797	469	23880	417	40	2019	1.0305	1.0075	25512	473	24608	420	2026	1.0746	1.075	27415	508	26444	452	4	0	4	4	0	27419	508	26448	452	0.0%	0.0%		

Annex B Figures

Page intentionally blank

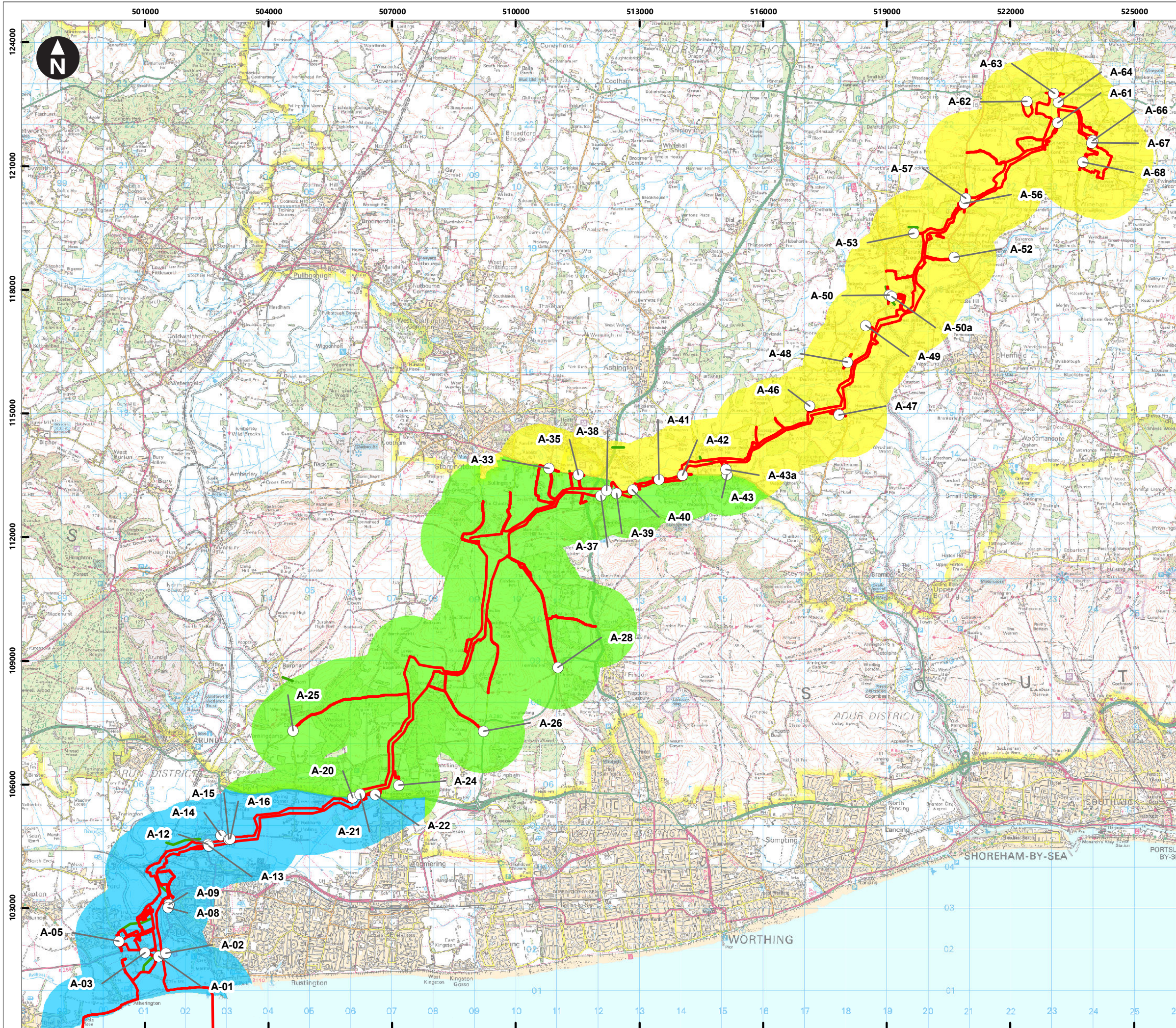

Service Layer Credits: Contains OS data © Crown Copyright and database right 2020
 © Crown copyright and database rights (2023)
 Ordnance Survey 0100031673

Key

- Proposed DCO Order Limits
- Access from public highway during construction
- Access track
- TCC A-62, A-63, A-68
- TCC A-39
- TCC A-05

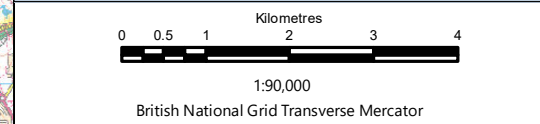

Rampion Extension Development

Rampion 2 Offshore Wind Farm
 Figure 23.2.1 Onshore route Temporary Construction Compound (TCC) Sections and accesses from public highways

Traffic Generation Technical Note
 Environmental Statement

System Identifier: 42285-WSPE-ES-ON-FG-OT-8516	Version: 1.0
---	-----------------

Company: WSP	Drawn By: SHEPS	Chk/Prvrd: SUTET	Drawn Date: 08/08/2023	Status: Draft
-----------------	--------------------	---------------------	---------------------------	------------------

Annex C

Construction Traffic Peak Movements

This table shows, for each access, the week when the total number of vehicle movements (all vehicles) is highest, and how many vehicles this would be. Additionally it seeks to represent the duration of this effect, by showing the number of weeks at which vehicle movements would be at or above 90% of this peak, as well as 75% and 50%.

Access	Peak Week	Two-way movements						
		Total (LGV+HGV)	>=90% Threshold	No. of Weeks	>=75% Threshold	No. of Weeks	>=50% Threshold	No. of Weeks
A-01	70	244	220	1	183	5	122	16
A-05	72	1498	1348	2	1124	7	749	23
A-09	161	244	220	1	183	2	122	5
A-12	162	246	221	1	185	1	123	1
A-13	64	226	203	1	170	2	113	2
A-16	70	282	254	3	212	9	141	15
A-21	61	224	202	4	168	4	112	23
A-26	70	310	279	4	233	10	155	17
A-33	85	302	272	3	227	3	151	5
A-35	60	88	79	2	66	2	44	3
A-39	83	1656	1490	1	1242	2	828	29
A-40	116	222	200	1	167	5	111	13
A-42	122	128	115	2	96	2	64	4

Access	Peak Week	Two-way movements						
		Total (LGV+HGV)	>=90% Threshold	No. of Weeks	>=75% Threshold	No. of Weeks	>=50% Threshold	No. of Weeks
A-43	162	248	223	3	186	6	124	23
A-47	157	172	155	1	129	1	86	9
A-48	158	210	189	2	158	2	105	15
A-50	90	196	176	3	147	4	98	12
A-53	162	242	218	2	182	2	121	2
A-56	98	198	178	1	149	1	99	12
A-57	111	222	200	3	167	5	111	14
A-61	160	154	139	2	116	9	77	14
A-62	125	866	779	2	650	2	433	12
A-63	83	900	810	20	675	29	450	99
A-64	162	286	257	1	215	2	143	2
A-67	125	186	167	2	140	2	93	5
A-68	127	272	245	3	204	9	136	25

Page intentionally blank

